

# **COILMASTER**

## **CORPORATION**

*Reliability in Heat Transfer Products*

# **Remote Air-Cooled Condensers**

**Catalog 120-1**

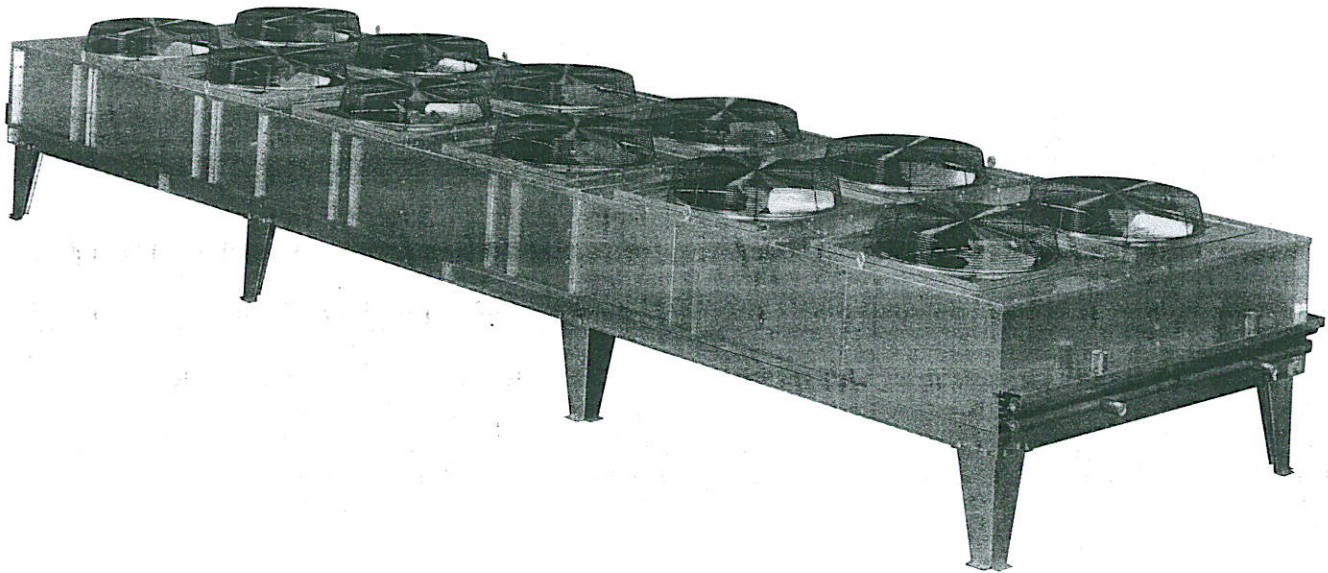

**1 Through 212 Nominal Tons**



**P.O. Box 228 • 50 Commerce Lane • Bolivar, TN 38008**  
**888-302-6049 • (731) 658-2524**  
**Fax (731) 658-8911**  
**[www.coilmastercorp.com](http://www.coilmastercorp.com)**

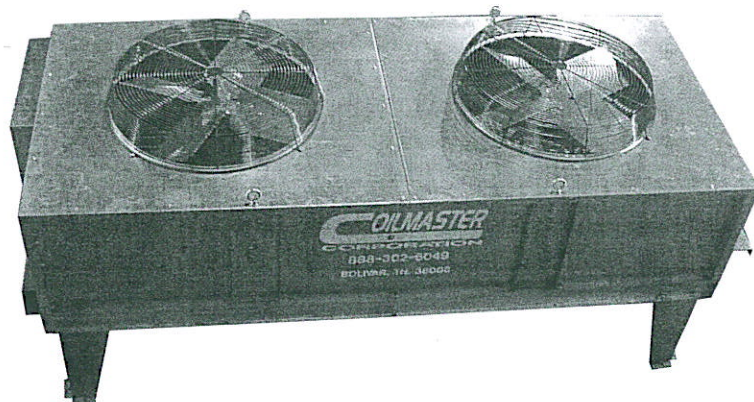

Why should your next condenser come from Coilmaster?

One word - RELIABILITY!

Our modern manufacturing facility and knowledgeable production technicians ensure a well made, quality product. At Coilmaster we begin with the best materials. Then we meticulously manufacture each part to our exacting standards. The final process is an intense testing procedure that assures each product performs to our high standard of excellence.

All of this means that when you install a condenser from Coilmaster, you are assured that our product is reliable.

We believe that you will like doing business with Coilmaster. We build almost any type of condenser that you might require and can supply any combination of materials, as well as any type of control package that you might need. The best part about doing business with Coilmaster is that you will not have to sacrifice service to get the product that you want. And if you require a special delivery date, we can work to your deadline.

We hope that you contact Coilmaster for your next condenser. We guarantee that you will be satisfied with our service and products.

**Coils**

- Aluminum tube sheets and galvanized casing Standard
- 1/2" O.D. copper tubes expanded into aluminum fins Standard
- Special fin materials:
  - .010 thick aluminum Optional
  - .006 thick copper Optional
  - Polyester-coated fin stock Optional
- Epoxy or phenolic-coated coils Optional
- Subcooling circuits and multi-circuiting Optional

**Fan Section**

- Aluminum fan blades with painted steel hubs Standard
- Fully baffled fan module Standard
- Fan motors mounted on motor rails Standard
- Hinged venturi panels for ease of coil cleaning and maintenance Optional
- Open type 6-pole (1140 RPM) energy-efficient motors Standard

**Control Panel**

- Weatherproof enclosure with all motor leads pulled Standard
- Ambient temperature or pressure fan cycling controls Optional
- Control circuit toggle switches Optional
- Mounted disconnect switch Optional
- Control transformer Optional
- Motor fusing Optional

**General Construction**

- Galvanized steel frame and cabinet Standard
- Aluminum cabinet with galvanized steel frame Optional
- Vertical air discharge configuration Standard
- Horizontal air discharge configuration \* Optional

**Shipping**

- Coils shipped with nitrogen holding charge Standard
- Legs mounted on models CVH-015 and larger (vertical air discharge) Standard

\*Models 001 through 012 are shipped with legs that can be mounted for either horizontal or vertical air flow. All other models are specifically built for either vertical or horizontal air flow.

**Condenser Nomenclature**

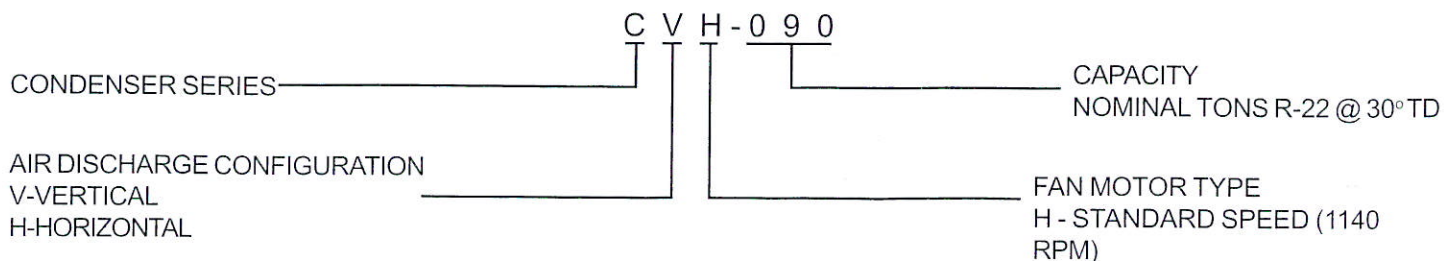

Table 1: Performance Data at Standard Fin Spacing (MBH)

Refrigerant R-22

SINGLE FAN-WIDTH UNITS						
MODEL CVH/CHH	TD					
	1	10	15	20	25	30
001	0.7	6.8	10.3	13.7	17.1	20.5
002	1.2	11.7	17.6	23.4	29.3	35.1
004	2.1	20.5	30.8	41.0	51.3	61.5
005	2.5	25.1	37.7	50.3	62.8	75.4
008	3.8	37.7	56.6	75.4	94.3	113.1
010	5.0	50.3	75.4	100.5	125.7	150.8
012	5.6	56.3	84.4	112.5	140.7	168.8
015	7.3	72.7	109.1	145.4	181.8	218.2
016	8.3	82.5	123.8	165.1	206.3	247.6
020	9.5	95.4	143.0	190.7	238.4	286.1
022	10.6	106.1	159.2	212.3	265.3	318.4
025	12.1	121.3	181.9	242.6	303.2	363.9
028	13.5	135.1	202.7	270.2	337.8	405.3
031	15.1	150.7	226.0	301.3	376.7	452.0
036	17.4	174.1	261.2	348.2	435.3	522.3
041	20.2	202.3	303.4	404.5	505.7	606.8
046	22.5	225.3	338	450.6	563.3	675.9
050	24.5	245.1	367.7	490.2	612.8	735.3
053	27.0	269.6	404.4	539.3	674.1	808.9
059	30.0	300.5	450.7	600.9	751.2	901.4
065	32.6	326.1	489.1	652.1	815.2	978.2
069	34.7	347.0	520.5	693.9	867.4	1040.9
077	38.0	379.5	569.3	759.0	948.8	1138.5
081	40.2	401.9	602.8	803.7	1004.7	1205.6
084	41.5	415.2	622.9	830.5	1038.1	1245.7
088	43.5	435.4	653.1	870.8	1088.5	1306.2
096	48.2	482.1	723.2	964.2	1205.3	1446.3
098	49.4	494.4	741.6	988.8	1236	1483.2
105	52.5	525.2	787.9	1050.5	1313.1	1575.7

DOUBLE-FAN-WIDTH UNITS						
047	24.3	242.6	363.9	485.2	606.5	727.8
054	27.0	269.3	404.0	539.3	674.1	808.0
060	30.1	301.1	451.6	602.1	752.7	903.2
066	32.6	326.0	489.0	651.9	814.9	977.9
070	34.7	347.1	520.7	694.2	867.8	1041.3
075	36.4	364.1	546.2	728.2	910.3	1092.3
080	40.3	403.3	605.0	806.6	1008.3	1209.9
085	42.6	425.9	638.9	851.9	1064.8	1277.8
090	45.2	452.4	678.6	904.8	1131.0	1357.2
099	49.4	494.3	741.5	988.7	1235.8	1483.0
106	52.5	525.0	787.5	1050.0	1312.5	1575.0
108	53.7	537.4	806.2	1074.9	1343.6	1612.3
121	60.1	601.4	902.2	1202.9	1503.6	1804.7
132	65.2	652.1	978.2	1304.2	1630.3	1956.3
140	69.4	693.6	1040.4	1387.2	1734.0	2080.8
154	76.1	760.8	1141.3	1521.7	1902.1	2282.5
162	80.4	804.2	1206.3	1608.4	2010.5	2412.6
170	83.1	830.9	1246.4	1661.8	2077.3	2492.7
177	87.5	875.1	1312.7	1750.2	2187.8	2625.3
193	96.5	965.1	1447.6	1930.1	2412.7	2895.2
200	98.9	989.0	1483.6	1978.1	2472.6	2967.1
212	105.1	1050.6	1575.9	2101.1	2626.4	3151.7

Refrigerant R-404A & 507

SINGLE FAN-WIDTH UNITS						
MODEL CVH/CHH	TD					
	1	10	15	20	25	30
001	0.7	6.8	10.3	13.7	17.1	20.5
002	1.2	11.7	17.6	23.4	29.3	35.1
004	2.1	20.5	30.8	41.0	51.3	61.5
005	2.5	24.5	36.8	49.0	61.3	73.5
008	3.7	37.2	55.9	74.5	93.1	111.7
010	4.9	49.0	73.5	98.0	122.5	147.0
012	5.5	54.9	82.3	109.8	137.2	164.6
015	7.2	71.5	107.3	143.1	178.9	214.6
016	8.1	81.3	122.0	162.7	203.4	244.0
020	9.3	93.1	139.7	186.2	232.8	279.3
022	10.4	103.9	155.8	207.8	259.7	311.6
025	11.9	118.6	177.9	237.2	296.5	355.7
028	13.2	132.3	198.5	264.6	330.8	396.9
031	14.8	148.0	222.0	296.0	370.0	443.9
036	17.1	170.5	255.8	341.0	426.3	511.6
041	19.8	198.0	296.9	395.9	494.9	593.9
046	22.1	220.5	330.8	441.0	551.3	661.5
050	24.0	240.1	360.2	480.2	600.3	720.3
053	26.5	264.6	396.9	529.2	661.5	793.8
059	29.4	294.0	441.0	588.0	735.0	882.0
065	31.9	319.5	479.2	639.0	798.7	958.4
069	34.0	340.1	510.1	680.1	850.2	1020.2
077	37.2	372.4	558.6	744.8	931.0	1117.2
081	39.4	394.0	590.9	787.9	984.9	1181.9
084	40.7	406.7	610.1	813.4	1016.8	1220.1
088	42.6	426.3	639.5	852.6	1065.8	1278.9
096	47.2	472.4	708.5	944.7	1180.9	1417.1
098	48.4	484.1	726.2	968.2	1210.3	1452.4
105	51.5	514.5	771.8	1029.0	1286.3	1543.5

DOUBLE FAN-WIDTH UNITS						
047	23.8	238.1	357.2	476.3	595.4	714.4
054	26.5	264.6	396.9	529.2	661.5	793.8
060	29.5	295.0	442.5	590.0	737.5	884.9
066	31.9	319.5	479.2	639.0	798.7	958.4
070	34.0	340.1	510.1	680.1	850.2	1020.2
075	35.7	356.7	535.1	713.4	891.8	1070.2
080	39.5	394.9	592.4	789.9	987.4	1184.8
085	41.7	417.5	626.2	835.0	1043.7	1252.4
090	44.3	443.0	664.4	885.9	1107.4	1328.9
099	48.4	484.1	726.2	968.2	1210.3	1452.4
106	51.5	514.5	771.8	1029.0	1286.3	1543.5
108	52.6	526.3	789.4	1052.5	1315.7	1578.8
121	58.9	589.0	883.5	1178.0	1472.5	1766.9
132	63.9	639.0	958.4	1277.9	1597.4	1916.9
140	68.0	680.1	1020.2	1360.2	1700.3	2040.4
154	74.6	745.8	1118.7	1491.6	1864.5	2237.3
162	78.8	787.9	1181.9	1575.8	1969.8	2363.8
170	81.4	814.4	1221.6	1628.8	2036.0	2443.1
177	85.8	857.5	1286.3	1715.0	2143.8	2572.5
193	94.6	945.7	1418.6	1891.4	2364.3	2837.1
200	96.9	969.2	1453.8	1938.4	2423.1	2907.7
212	103.0	1030.0	1545.0	2060.0	2575.0	3089.9

For R-134A selections, divide the required capacity by 0.95, then select the proper unit from the R-22 table using the corrected capacity.

**Table 2: Performance Data at Alternate Fin Spacing (MBH/°F.TD)**  
Refrigerant R-22

SINGLE FAN-WIDTH UNITS				
MODEL CVH/CH-H	8 FPI	10 FPI	12 FPI	14FPI
001	<b>0.68</b>	--	--	--
002	<b>1.17</b>	--	--	--
004	--	<b>2.01</b>	--	--
005	--	<b>2.51</b>	--	--
008	<b>3.77</b>	--	--	--
010	--	<b>5.03</b>	--	--
012	--	<b>5.63</b>	--	--
015	<b>7.27</b>	see 016	--	--
016	see 015	<b>8.25</b>	--	--
020	<b>9.54</b>	see 022	--	--
022	see 020	<b>10.61</b>	--	--
025	9.13	10.26	11.28	<b>12.13</b>
028	12.20	<b>13.51</b>	see 031	see 031
031	see 028	see 028	14.32	<b>15.07</b>
036	14.76	15.87	16.71	<b>17.41</b>
041	<b>18.27</b>	<b>20.23</b>	see 046	see 046
046	see 041	see 041	21.4	<b>22.53</b>
050	21.72	23.36	<b>24.51</b>	--
053	24.34	<b>26.96</b>	see 059	see 059
059	see 053	see 053	28.55	<b>30.05</b>
065	28.90	31.08	<b>32.61</b>	see 069
069	see 065	see 065	see 065	<b>34.7</b>
077	30.31	33.56	36.05	<b>37.95</b>
081	37.38	<b>40.19</b>	see 084	see 088
084	see 081	see 081	<b>41.52</b>	see 088
088	see 081	see 081	see 084	<b>43.54</b>
096	44.84	<b>48.21</b>	see 098	see 105
098	see 096	see 096	<b>49.44</b>	see 105
105	see 096	see 096	see 098	<b>52.52</b>

DOUBLE FAN-WIDTH UNITS				
MODEL	8 FPI	10 FPI	12 FPI	14FPI
047	18.27	20.53	22.56	<b>24.26</b>
054	24.32	<b>26.93</b>	see 060	see 060
060	see 054	see 054	28.60	<b>30.11</b>
066	28.90	31.07	<b>32.60</b>	see 070
070	see 066	see 066	see 066	<b>34.71</b>
075	27.42	30.81	33.86	<b>36.41</b>
080	36.42	<b>40.33</b>	see 085	see 090
085	see 080	see 080	<b>42.59</b>	see 090
090	see 080	see 080	see 085	<b>45.24</b>
099	43.67	46.96	<b>49.43</b>	see 106
106	see 099	see 099	see 099	<b>52.50</b>
108	48.53	<b>53.74</b>	see 121	see 121
121	see 108	see 108	57.15	<b>60.16</b>
132	57.61	61.95	<b>65.21</b>	see 140
140	see 132	see 132	see 132	<b>69.36</b>
154	60.70	67.22	72.28	<b>76.08</b>
162	74.79	<b>80.42</b>	see 170	see 177
170	see 162	see 162	<b>83.09</b>	see 177
177	see 162	see 162	see 170	<b>87.51</b>
193	89.75	<b>96.51</b>	see 200	see 212
200	see 193	see 193	<b>98.90</b>	see 212
212	see 193	see 193	see 200	<b>105.06</b>

Notes: 1.) Performance in bold face type indicates standard fins per inch - Regular type indicates alternate fins per inch. 2.) A fin spacing for a given model is available if the capacity is shown. Otherwise, refer to the model indicated in the table. 3.) For R-134A selections, divide the required capacity by 0.95, then select the proper unit from the R-22 table using the corrected capacity. 4.) For R-404A & 507 selections, multiply R-22 capacities by 0.98.

**Table 3: Fan & Motor Data**

SINGLE FAN-WIDTH UNITS									
UNIT SIZE	FAN DATA			MOTOR DATA					
	QTY	DIA.(IN)	TOTAL CFM	NOM. HP	MIN. CIRCUIT AMPACITY				SOUND LEVELS (DBA)
					208-230 1 PH	208-230 3 PH	460 3 PH	575 3 PH	
001	1	18	3100	1/2	15	15	15	15	70
002	1	18	2550	1/2	15	15	15	15	70
004	1	22	4350	1/2	15	15	15	15	71
005	2	22	3900	1/2	15	15	15	15	71
008	2	22	8900	1/2	15	15	15	15	72
010	2	22	7800	1/2	15	15	15	15	72
012	2	22	7100	1/2	15	15	15	15	73
015	2	26	15200	1	15	15	15	15	73
016	2	26	15000	1	15	15	15	15	76
020	2	26	14850	1	15	15	15	15	76
022	2	26	14600	1	15	15	15	15	76
025	2	30	22400	1 1/2	N/A	15	15	15	76
028	2	30	22000	1 1/2	N/A	15	15	15	76
031	2	30	21200	1 1/2	N/A	15	15	15	76
036	2	30	20000	1 1/2	N/A	15	15	15	76
041	3	30	33000	1 1/2	N/A	21.1	15	15	78
046	3	30	31800	1 1/2	N/A	21.1	15	15	78
050	3	30	30900	1 1/2	N/A	21.1	15	15	78
053	4	30	44000	1 1/2	N/A	27.6	15	15	80
059	4	30	42400	1 1/2	N/A	27.6	15	15	80
065	4	30	41200	1 1/2	N/A	27.6	15	15	80
069	4	30	40000	1 1/2	N/A	27.6	15	15	80
077	5	30	53000	1 1/2	N/A	34.1	17.3	15	81
081	5	30	52630	1 1/2	N/A	34.1	17.3	15	81
084	5	30	51500	1 1/2	N/A	34.1	17.3	15	81
088	5	30	50000	1 1/2	N/A	34.1	17.3	15	81
096	6	30	63150	1 1/2	N/A	40.6	20.6	15	82
098	6	30	61800	1 1/2	N/A	40.6	20.6	15	82
105	6	30	60000	1 1/2	N/A	40.6	20.6	15	82

DOUBLE FAN-WIDTH UNITS									
047	4	30	44800	1 1/2	N/A	27.6	15	15	80
054	4	30	44000	1 1/2	N/A	27.6	15	15	80
060	4	30	42400	1 1/2	N/A	27.6	15	15	80
066	4	30	41200	1 1/2	N/A	27.6	15	15	80
070	4	30	40000	1 1/2	N/A	27.6	15	15	80
075	6	30	67200	1 1/2	N/A	40.6	20.6	15	82
080	6	30	66000	1 1/2	N/A	40.6	20.6	15	82
085	6	30	64800	1 1/2	N/A	40.6	20.6	15	82
090	6	30	63600	1 1/2	N/A	40.6	20.6	15	82
099	6	30	61800	1 1/2	N/A	40.6	20.6	15	82
106	6	30	60000	1 1/2	N/A	40.6	20.6	15	82
108	8	30	88000	1 1/2	N/A	53.6	27.2	19.8	83
121	8	30	84800	1 1/2	N/A	53.6	27.2	19.8	83
132	8	30	82400	1 1/2	N/A	53.6	27.2	19.8	83
140	8	30	80000	1 1/2	N/A	53.6	27.2	19.8	83
154	10	30	106000	1 1/2	N/A	66.6	33.8	24.6	84
162	10	30	105250	1 1/2	N/A	66.6	33.8	24.6	84
170	10	30	103000	1 1/2	N/A	66.6	33.8	24.6	84
177	10	30	100000	1 1/2	N/A	66.6	33.8	24.6	84
193	12	30	126300	1 1/2	N/A	79.6	40.4	29.4	84
200	12	30	123600	1 1/2	N/A	79.6	40.4	29.4	84
212	12	30	120000	1 1/2	N/A	79.6	40.4	29.4	84

**Table 4: Heat Rejection Factors - Open Compressors**

EVAP TEMP °F	CONDENSING TEMPERATURE F°								
	90	95	100	105	110	115	120	125	130
-30	1.37	1.39	1.42	1.44	1.47	+	+	+	+
-20	1.33	1.35	1.37	1.39	1.42	1.44	1.47	+	+
-10	1.28	1.30	1.32	1.34	1.37	1.39	1.42	1.44	1.47
0	1.24	1.26	1.28	1.30	1.32	1.34	1.37	1.39	1.41
+10	1.21	1.23	1.24	1.26	1.28	1.30	1.32	1.34	1.36
+20	1.17	1.18	1.20	1.22	1.24	1.26	1.28	1.30	1.32
+30	1.14	1.15	1.17	1.18	1.20	1.22	1.24	1.25	1.27
+40	1.12	1.14	1.15	1.16	1.17	1.16	1.20	1.21	1.23
+50	1.09	1.11	1.12	1.13	1.14	1.16	1.17	1.19	1.20

**Table 5: Heat Rejection Factors  
Suction Cooled Semi-hermetic Compressors**

EVAP TEMP °F	CONDENSING TEMPERATURE F°								
	90	95	100	105	110	115	120	125	130
-40	1.66	1.70	1.73	1.76	1.80	1.90	2.00	+	+
-35	1.61	1.64	1.68	1.70	1.74	1.82	1.90	+	+
-30	1.57	1.60	1.62	1.65	1.68	1.74	1.80	+	+
-25	1.53	1.56	1.58	1.60	1.63	1.67	1.72	+	+
-20	1.49	1.51	1.53	1.55	1.58	1.61	1.65	+	+
-15	1.46	1.48	1.50	1.51	1.54	1.57	1.61	+	+
-10	1.42	1.44	1.46	1.48	1.50	1.53	1.57	1.60	1.64
-5	1.39	1.41	1.43	1.45	1.47	1.50	1.53	1.56	1.60
0	1.36	1.38	1.40	1.42	1.44	1.47	1.50	1.53	1.56
+5	1.33	1.35	1.37	1.39	1.41	1.43	1.46	1.49	1.52
+10	1.31	1.32	1.34	1.36	1.38	1.40	1.43	1.46	1.49
+15	1.28	1.30	1.32	1.33	1.35	1.37	1.40	1.43	1.46
+20	1.26	1.27	1.29	1.31	1.33	1.35	1.37	1.40	1.43
+25	1.24	1.25	1.27	1.29	1.31	1.33	1.35	1.37	1.40
+30	1.22	1.23	1.25	1.26	1.28	1.30	1.32	1.34	1.37
+35	1.20	1.21	1.23	1.25	1.26	1.27	1.29	1.31	1.34
+40	1.18	1.19	1.21	1.23	1.24	1.25	1.27	1.29	1.31
+45	1.16	1.17	1.19	1.21	1.22	1.23	1.25	1.26	1.28
+50	1.14	1.15	1.17	1.19	1.20	1.22	1.23	1.24	1.26

+= beyond the limits for single stage compressor application

**Table 6: Connection Sizing**

THR Per Unit Section (MBH)	Hot Gas (Inlet) Size (ODS)		Liquid (Outlet) Size (ODS)	
	R-22	R-404A	R-22	R-404A
3	5/8	5/8	5/8	5/8
6	5/8	5/8	5/8	5/8
9	5/8	5/8	5/8	5/8
12	5/8	5/8	5/8	5/8
18	5/8	5/8	5/8	5/8
24	5/8	7/8	5/8	5/8
36	7/8	7/8	5/8	5/8
48	7/8	7/8	5/8	5/8
60	7/8	1 1/8	5/8	7/8
72	1 1/8	1 1/8	7/8	7/8
90	1 1/8	1 1/8	7/8	7/8
120	1 1/8	1 3/8	7/8	1 1/8
180	1 3/8	1 5/8	1 1/8	1 3/8
240	1 5/8	1 5/8	1 3/8	1 3/8
300	1 5/8	1 5/8	1 3/8	1 3/8
360	2 1/8	2 1/8	1 5/8	1 5/8
480	2 1/8	2 1/8	1 5/8	1 5/8
600	2 1/8	2 5/8	1 5/8	2 1/8
720	2 5/8	2 5/8	2 1/8	2 1/8
840	2 5/8	2 5/8	2 1/8	2 1/8
960	2 5/8	2 5/8	2 1/8	2 1/8

Note: Use 404A sizes for R-502, 507 & 134A

**CONDENSER SELECTION**

Air-cooled condenser ratings are based on the total heat rejection of the refrigeration or air conditioning system. Total heat rejection is the sum of the net refrigeration effect and the heat of compression added to the refrigerant in the compressor.

Since the heat of compression varies with the design of the compressor, the manufacturer's data should be used whenever possible. However, if the data is not available from the manufacturer, factors may be used from Tables 4 and 5 to determine the heat of compression. The factors are to be used with the compressor capacity (or net refrigeration effect) to calculate the total heat rejection.

**ELEVATION CORRECTION**

Since elevation above sea level has an effect on the performance of air-cooled condensers, correction factors are used to adjust capacity to sea level conditions. Divide the required capacity by the appropriate correction factor in Table 7, and select the condenser from any of the capacity tables.

**SELECTION EXAMPLE**

Given:

Ambient air temperature = 95°

Maximum condensing temperature = 115°

Evaporator temperature = 35°

Refrigerant = R-22

Compressor capacity

(net refrigeration effect) = 351,000 BTUH

Compressor type: Suction-cooled semi-hermetic

Solution:

Use the factor from Table 5 for 115° condensing temperature and 35° evaporator temperature to calculate the heat of rejection required.

$351,000 \text{ BTUH} \times 1.27 = 445,770 \text{ BTUH}$

The selection is made for 20° TD (temperature difference). TD is the condensing temperature minus ambient temperature.

The condenser can be selected from Table 1 under the column headed R-22 at 20° TD. The correct selection of a single fan-width unit is a CVH-046 with a capacity of 450,600 BTUH.

**ALTERNATE FIN SPACING**

Performance data for condensers at alternate fin spacings are in Table 2 and is presented in MBH/1° TD only. The following illustrates the procedure for selecting a condenser at 10 fins per inch for the above example. First, the MBH/1° TD must be determined in order to select the proper unit.

$$455.8 \text{ MBH}/20^\circ \text{ TD} = 22.79 \text{ MBH}/1^\circ \text{ TD}$$

Using Table 2 under the 10 FPI heading, find the unit with the required capacity. The correct single fan-width unit that meets the requirement is a CVH-050.

**Table 7: Elevation Correction Factors**

ELEVATION (ft.)	CORRECTION FACTOR
1000	.94
2000	.93
3000	.90
4000	.88
5000	.86
6000	.83
8000	.79
10000	.75
12000	.71
14000	.66
16000	.62

**Table 8: Standard Refrigerant Charge**

UNIT SIZE	TOTAL UNIT CHARGE LBS. R-22	TOTAL UNIT CHARGE LBS. R-404A/507
SINGLE-FAN WIDTH UNITS		
001	0.85	0.72
002	1.70	1.40
004	2.40	2.00
005	3.60	3.10
008	4.80	4.10
010	7.20	6.10
012	9.60	8.20
015	11.60	9.30
016	11.60	9.30
020	17.40	14.80
022	17.40	14.80
025	11.60	9.90
028	17.40	14.80
031	17.40	14.80
036	23.10	19.60
041	26.10	22.20
046	26.00	22.10
050	34.70	29.50
053	34.70	29.50
059	34.70	29.50
065	46.30	39.40
069	46.30	39.40
077	43.40	36.90
081	57.80	49.10
084	57.80	49.10
088	57.80	49.10
096	69.40	59.00
098	69.40	59.00
105	69.40	59.00

DOUBLE FAN WIDTH UNITS		
047	23.10	19.60
054	34.70	29.50
060	37.70	29.50
066	46.30	39.40
070	46.30	39.40
075	34.70	29.50
080	52.10	44.30
085	52.10	44.30
090	52.10	44.30
099	69.40	59.00
106	69.40	59.00
108	69.40	59.00
121	69.40	59.00
132	92.60	78.70
140	92.60	78.70
154	86.80	73.80
162	115.70	98.30
170	115.70	98.30
177	115.70	98.30
193	138.80	118.00
200	138.80	118.00
212	138.80	118.00

Note: For R-134A, multiply R-22 charge by 1.02

### TYPICAL WIRING - SINGLE PHASE UNITS

#### Power Wiring

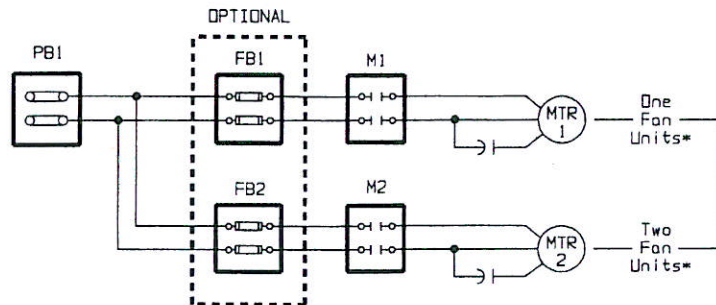

#### Control Wiring

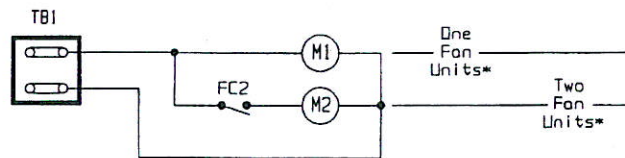

#### LEGEND

- FB1 - FB2 .....Fuse Blocks
- FC2 - FC2 .....Fan Cycling Controls
- M1 - M2 .....Fan Motor Contactors
- MTR1 - MTR2 .....Fan Motors
- TB1 .....Control Terminal Block
- PB1 .....Power Terminal Block

#### NOTES

1. Motor 1 is always located at the header end of the unit.
2. PB1 is not furnished on single fan units.
3. Field control wiring connections are made to terminal block TB1.
4. Holding coils can be furnished in most voltages, including 24, 115, 208-230 or 460 volts.
5. Fan cycling controls FC2 and FC3 can be furnished either as ambient temperature controls or pressure controls.

Table 9: Motor Amps.

ELECTRICAL CHARACTERISTICS	MOTOR HORSEPOWER		
	1/2	1	1 1/2
206-230/1/60	2.5 a	4.9 a	N/A
206-230/3/60	2.0 a	4.0 a	6.5 a
460/3/60	1.0 a	2.0 a	3.3 a
575/3/60	1.0 a	1.8 a	2.4 a

208-230V motors are usable on 190-220V, 50 HZ power. 460V motors are usable on 380-415V, 50HZ power.

# TYPICAL WIRING - THREE PHASE UNITS

## SINGLE FAN-WIDTH UNITS

## DOUBLE FAN-WIDTH UNITS

### Power Wiring

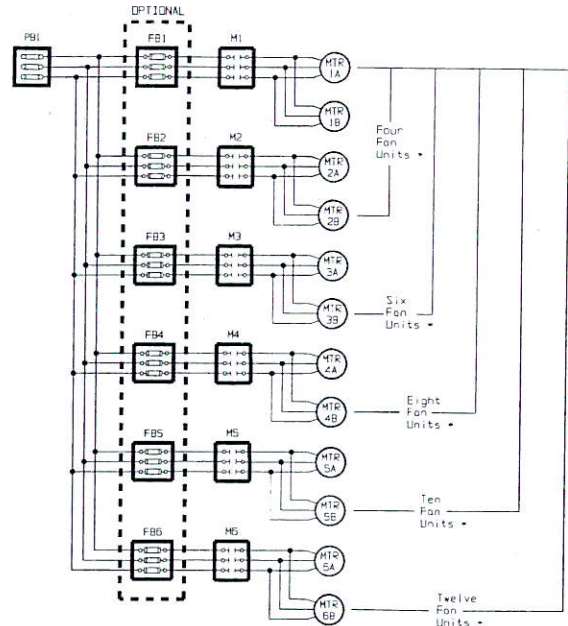
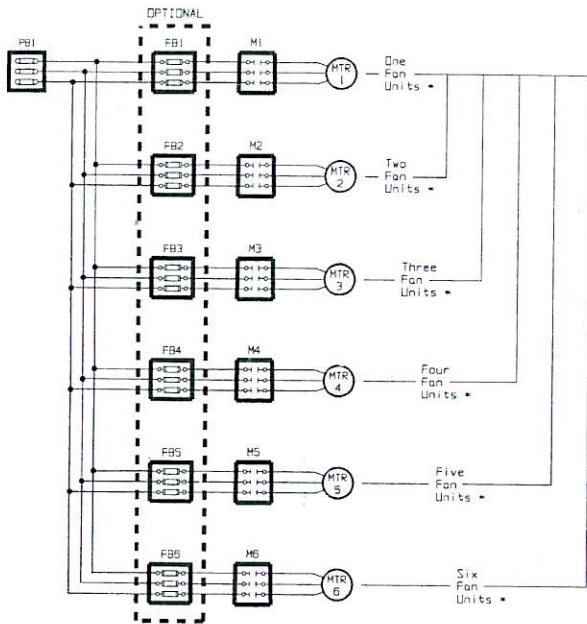

### Control Wiring

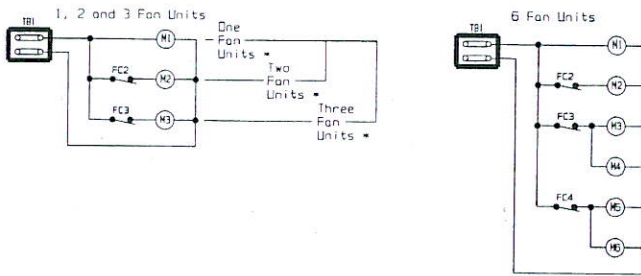

### Control Wiring

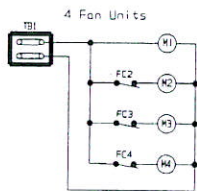
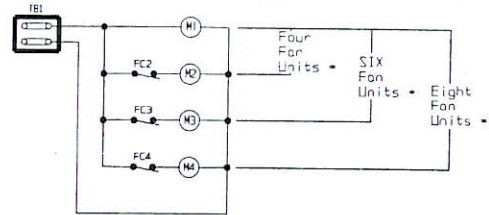

### LEGEND

- FB1 - FB6 .....Fuse Blocks
- FC2 - FC4 .....Fan Cycling Controls
- M1 - M6 .....Fan Motor Contactors
- MTR1 - MTR6 .....Fan Motors
- TB1 .....Control Terminal Block
- PB1 .....Power Terminal Block

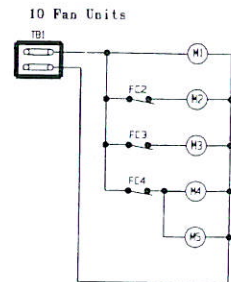

### NOTES

1. Motor 1 is always located at the header end of the unit.
2. PB1 is not furnished on single fan units.
3. Field control wiring connections are made to terminal block TB1.
4. Holding coils can be furnished in most voltages, including 24, 115, 208-230 or 460 volts.
5. Fan cycling controls FC2 and FC3 can be furnished either as ambient temperature controls or pressure controls.

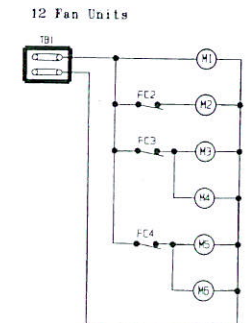
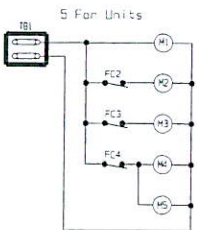

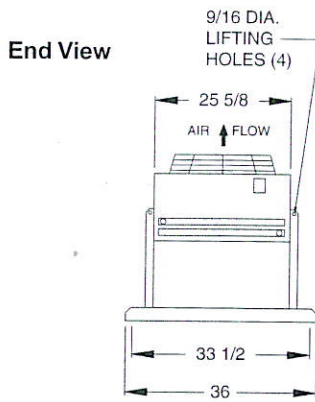

**CVH-001 thru 002**

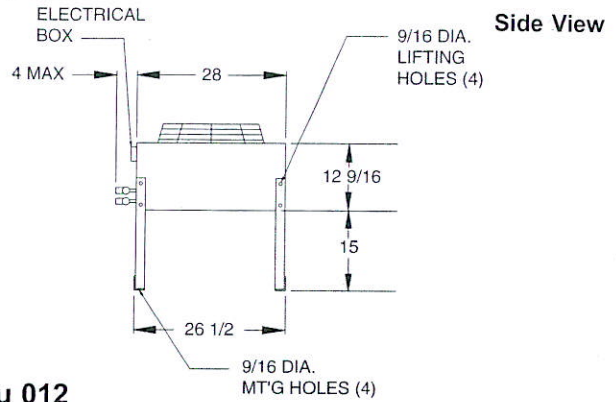

**CVH-004 thru 012**

**End View**

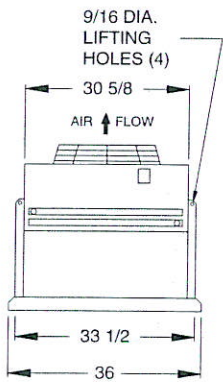

**Side View CVH-004 thru 005**

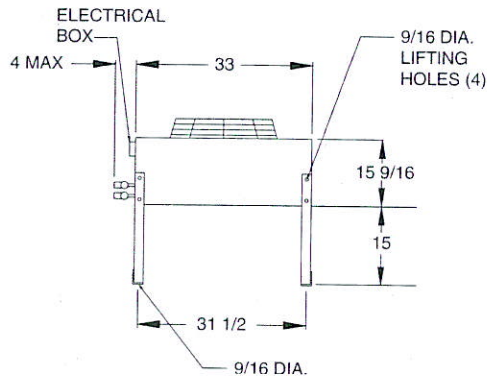

**Side View CVH-008 thru 012**

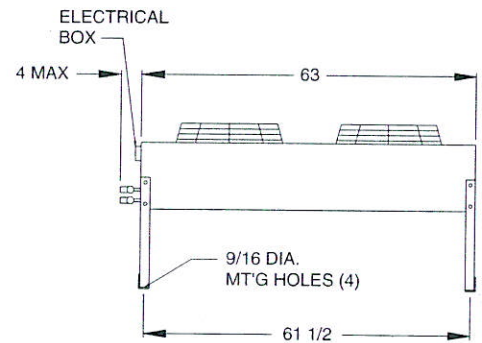

### Leg Details

**Vertical air discharge models CVH-015 thru 212**

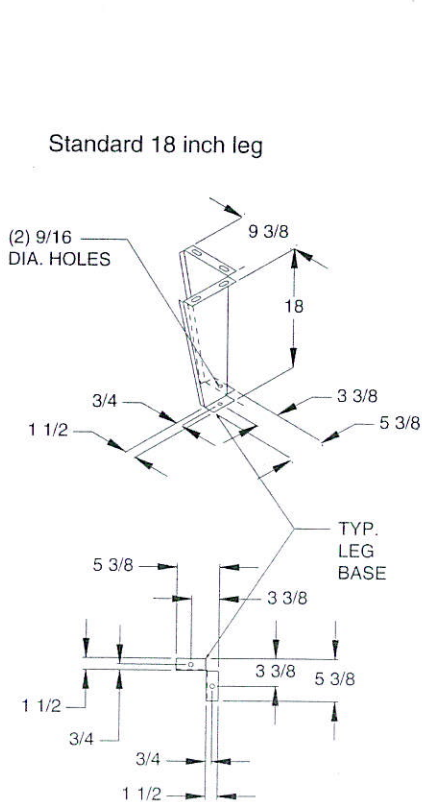

**Optional 30 inch leg**

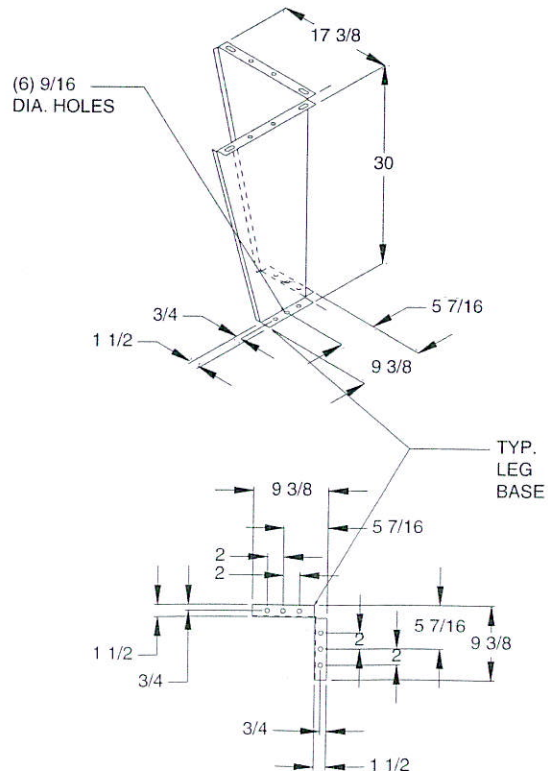

CVH-015 thru 212

End View  
Single Fan-Width  
Units

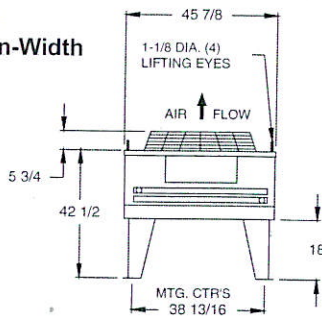

Side View

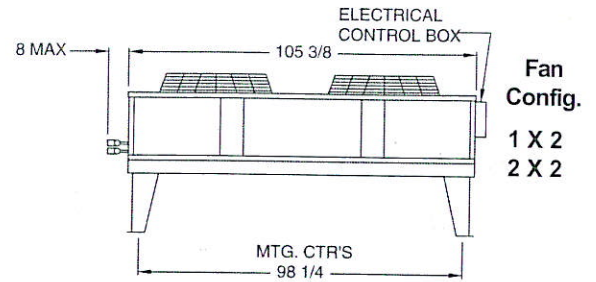

End View  
Double Fan-Width  
Units

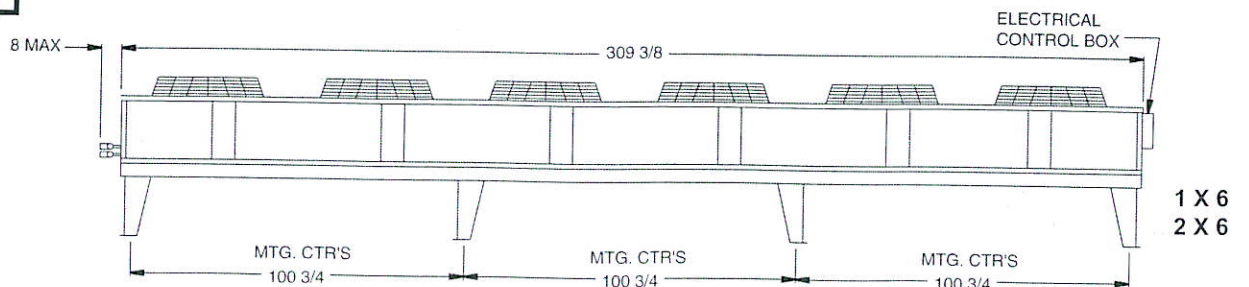
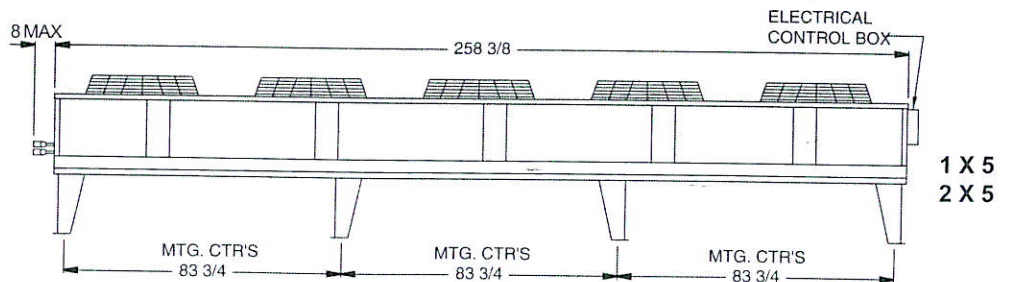
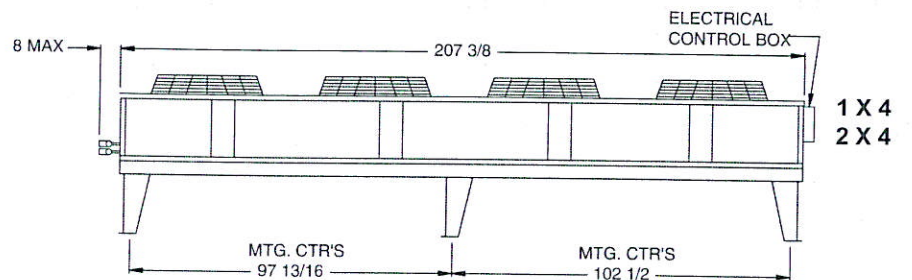
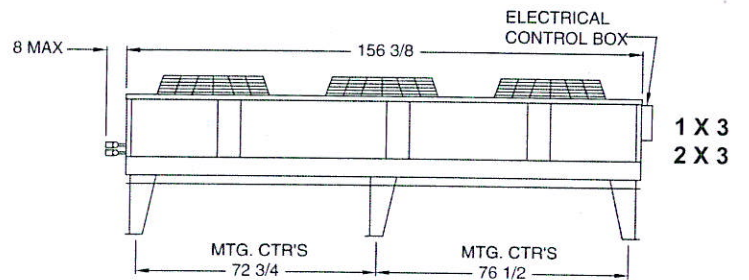
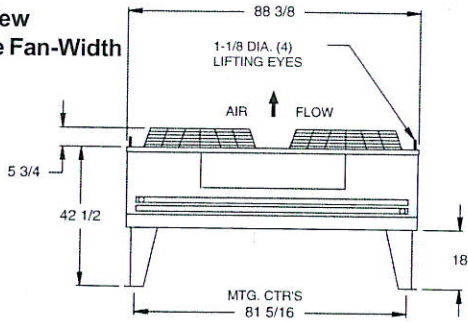

UNIT WEIGHTS SINGLE FAN WIDTH		
CVH	NET WT. LBS.	FAN CONFIG.
001	109	1
002	121	1
004	144	1
005	160	1
008	234	1 x 2
010	259	1 x 2
012	283	1 x 2
015	510	1 x 2
016	518	1 x 2
020	536	1 x 2
022	566	1 x 2
025	580	1 x 2
028	630	1 x 2
031	650	1 x 2
036	730	1 x 2
041	900	1 x 3
046	930	1 x 3
050	1010	1 x 3
053	1135	1 x 4
059	1201	1 x 4
065	1327	1 x 4
066	1360	1 x 4
077	1582	1 x 5
081	1654	1 x 5
084	1676	1 x 5
088	1698	1 x 5
096	2002	1 x 6
098	2030	1 x 6
105	2052	1 x 6

UNIT WEIGHTS DOUBLE FAN WIDTH		
CVH	NET WT. LBS.	FAN CONFIG.
047	1080	2 x 2
054	1130	2 x 2
060	1190	2 x 2
066	1300	2 x 2
070	1330	2 x 2
075	1580	2 x 3
080	1650	2 x 3
085	1710	2 x 3
090	1740	2 x 3
099	1870	2 x 3
106	1910	2 x 3
108	2180	2 x 4
121	2300	2 x 4
132	2539	2 x 4
140	2590	2 x 4
154	2980	2 x 5
182	3110	2 x 5
170	3140	2 x 5
177	3080	2 x 5
193	3730	2 x 6
200	3770	2 x 6
212	3820	2 x 6

**General**

Coilmaster model CVH and CHH units shall be furnished as per the following specifications in vertical airflow (CVH) or horizontal airflow (CHH). Units shall be ETL listed.

**Unit Cabinets**

- Housing shall be constructed of heavy-gauge steel for maximum rigidity and corrosion protection. Optional heavy-gauge aluminum cabinet shall be provided upon request.
- All multiple fan units shall have individual fan sections, separated by full width baffles to prevent air bypass and provide additional casing rigidity.
- All end panels and tube supports shall be constructed from heavy gauge aluminum to eliminate tube leaks at the tube sheets.
- Unit sizes CVH/CHH-015 and larger shall be provided with lifting eyes for rigging.
- Unit sizes CVH/CHH-001 through 012 shall be provided with legs for field assembly for either horizontal or vertical airflow.
- Unit sizes CVH-015 through 212 shall be provided with 10 gauge galvanized steel legs factory-mounted (vertical airflow units) for convenient unit installation.
- Unit sizes CHH-015 through 140 can be supplied for horizontal airflow. Legs for horizontal airflow units shall be shipped loose for field assembly.

**Condenser Coil**

- Coils shall be constructed of seamless 1/2 inch O.D. copper tubing on a staggered pattern.
- All tubes shall be mechanically expanded into full-collared plate-type aluminum (or optional copper) fins for permanent contact and maximum heat transfer efficiency.
- All coils shall be leak tested at 500 psig with dry nitrogen and shipped with a nitrogen holding charge.

**Fans**

- Fans shall be propeller type with aluminum blades and painted steel hubs. Fans shall be dynamically balanced and factory run tested before shipping.
- Fans shall have set screw that seats onto keyway on the shafts.

**Fan Guards**

- Fan guards shall be heavy gauge steel wire with painted finish for maximum protection and attractive appearance.

**Fan Motors**

- Fan motors shall be heavy duty PSC or three phase open drip-proof with built-in overload protection and permanently lubricated ball bearings.
- All motors shall have a rigid base mounted to 12 gauge galvanized steel rails. Motors shall be factory wired with leads terminating in a weather-tight enclosure.

*Coilmaster reserves the right to make design changes and modifications to its products without notice.*

**P.O. Box 228 • 50 Commerce Lane • Bolivar, TN 38008**  
**888-302-6049 • (731) 658-2524**  
**Fax (731) 658-8911**  
**www.coilmastercorp.com**