

A350P Series

Electronic Proportional Plus Integral Temperature Control

Description

The A350P Electronic Proportional Plus Integral Temperature Control Series has two proportional outputs of 0 to 10 VDC and 0 to 20 mA. This control is used in conjunction with the A99B Series (PTC silicon) Temperature Sensors. Two controls cover a temperature range from -30 to 250°F with an adjustable throttling range (proportional band) of 2 to 30F°.

Proportional plus integral (PI) control is an option to hold setpoint regardless of load shifts on the system. A temperature sensor (A99BC-25C) is included with each A350P control. The S350 Staging Module, D350 Display Module, and Y350R Power Module can be used with the A350P.

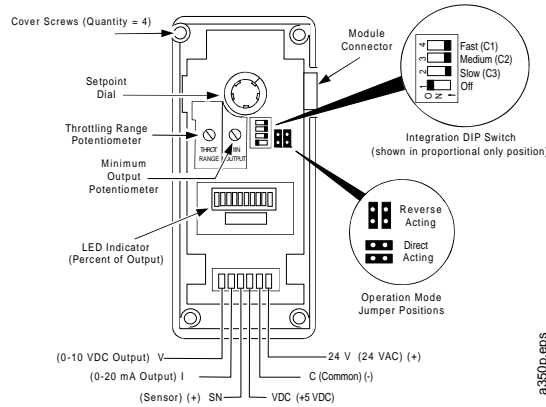

Interior of A350P



A350P

Features

- field-selectable proportional only or proportional plus integral control
- plug-together connectors and 35 mm DIN rail mounting eliminate wiring between models and reduce installation costs
- ten segment LED displays percent of output signal
- field-selectable reverse or direct-acting mode
- minimum output adjustable from 0 to 60%
- two models cover a wide setpoint range of -30 to 250°F (-35 to 121°C)

Selection Chart

Code Number	Output Signal	Range	Throttling Range	Sensor (Included)
A350PS-1C		-30 to 130°F		A99BC-25C
A350PT-1C	Proportional Voltage: 0 to 10 VDC and	-35 to 55°C	2 to 30F°	None
A350PS-2C	Proportional Current: 0 to 20 mA	90 to 250°F 30 to 121°C	1 to 17C°	A99BC-25C

Note: Specify code number from this selection chart, along with additional staging, display, and power modules, and temperature sensing enclosures, if required.

Applications

- modulating heating and cooling valves
- maintain mixed air duct temperature via damper modulation

Technical Specifications

A350P Electronic Temperature Control with Proportional Output		
Supply Voltage ¹	Transformer	20 to 30 VAC, 50/60 Hz, Class 2
	Y350R	120/240 VAC, 50/60 Hz
Proportional Output	0 to 10 VDC (550 ohm load minimum) and 0 to 20 mA. (600 ohm load maximum).	
Minimum Output	Adjustable from 0 to 60% of the output span	
Output Indication	A ten segment LED indicates percentage of output	
Control Action	Direct or reverse action is jumper selectable	
Power Consumption	3.2 VA	
Integration Constant	Three selectable rates fast, medium, slow and an Off position	
Ambient Temperature	Operating	-30 to 150°F (-34 to 66°C)
	Shipping	-40 to 185°F (-40 to 85°C)
Humidity	0 to 95% RH non-condensing	
Case and Cover Material	NEMA 1, high-impact thermoplastic	

1. Only one voltage source may be used.

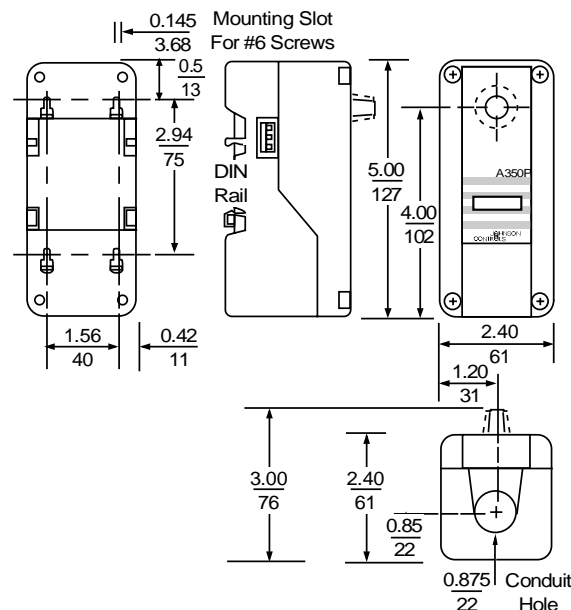

A350P Dimensions, in. (mm)