

Levitor Series II Air-Cooled Condensers

Operating and Installation Manual

TABLE OF CONTENTS

1	RECEIPT OF EQUIPMENT	2
1.1	INSPECTION.....	2
1.2	LOSS OF GAS HOLDING CHARGE.....	2
2	MODELS AND DIMENSIONS.....	2
2.1	UNIT MODELS.....	2
2.2	30" UNIT DIMENSIONS AND MOTOR AMPS.....	3
2.3	30" UNIT MOTOR AMPS.....	4
2.4	30" UNIT WEIGHTS AND REFRIGERANT CHARGES.....	5
2.5	24" UNIT DIMENSIONS AND MOTOR AMPS.....	6
3	UNIT LOCATION.....	7
4	RIGGING.....	8
5	UNIT ASSEMBLY.....	11
5.1	LEG ASSEMBLY FOR 30" FAN UNITS.....	11
5.2	OPTIONAL GRAVITY DAMPERS FOR 30" FAN UNITS.....	11
5.3	HORIZONTAL AIRFLOW BASE SUPPORT.....	12
5.4	LEG ASSEMBLY FOR 24" FAN UNITS.....	12
6	INSTALLATION AND PIPING.....	13
6.1	MOUNTING THE UNIT.....	13
6.2	INTERCONNECTING PIPING FOR DOUBLE WIDE UNITS.....	13
6.3	REFRIGERATION PIPING.....	13
6.4	HOLDBACK FLOODING CONTROL.....	16
7	ELECTRICAL.....	17
7.1	FIELD WIRING.....	17
7.2	MOTORS WIRED TO TERMINAL BLOCKS.....	17
7.3	MOTORS WIRED TO STANDARD FAN CYCLING CONTROL PANEL.....	18
7.4	FAN CYCLE OPERATION.....	19
7.5	CONTROL SETTINGS.....	19
7.6	TEMPERATURE SENSOR.....	19
8	INSPECTION AND CLEANING.....	22
9	REPLACEMENT PARTS LISTS.....	22

TABLES

Table 1	30" UNIT DIMENSIONS.....	3
Table 2	30" UNIT FULL LOAD MOTOR AMPS.....	4
Table 3	30" UNIT WEIGHTS AND REFRIGERANT CHARGES.....	5
Table 4	24" UNIT DIMENSIONS, AMPS, AND WEIGHTS.....	6
Table 5	24" REFRIGERANT LINE SIZING.....	15
Table 6	CONTROL PANEL SETTINGS – PRESSURE SENSING.....	20
Table 7	CONTROL PANEL SETTINGS – TEMPERATURE SENSING.....	21
Table 8	TYPICAL REPLACEMENT PART NUMBERS.....	22
Table 9	MISCELLANIOUS REPLACEMENT PART NUMBERS.....	23

FIGURES

Figure 1	30" UNIT DRAWINGS.....	3
Figure 2	24" UNIT DIMENSIONS.....	6
Figure 3	LOCATION REQUIREMENTS.....	7
Figure 4	RIGGING FOR 30" FAN UNITS.....	8
Figure 5	RIGGING FOR 30" FAN UNITS WITH RECEIVERS.....	9
Figure 6	RIGGING FOR 24" FAN UNITS.....	10
Figure 7	STANDARD 22" & 42" LEG ASSEMBLY.....	11
Figure 8	GRAVITY DAMPER ASSEMBLY.....	11
Figure 9	42" LEG & BRACING ASSEMBLY FOR 24" FAN UNITS.....	12
Figure 10	UNIT MOUNTING AND PIPING.....	14
Figure 11	DOUBLE RISER DISCHARGE ARRANGEMENT.....	16
Figure 12	HOLDBACK FLOODING CONTROL ARRANGEMENTS.....	16
Figure 13	TERMINAL BLOCK ONLY WIRING DIAGRAMS (NC – C444).....	17
Figure 14	INDIVIDUAL FAN MOTOR CYCLING WIRING DIAGRAM (-311).....	18
Figure 15	FAN MOTOR CYCLING IN PAIRS WIRING DIAGRAM (-331).....	18

1 RECEIPT OF EQUIPMENT

1.1 INSPECTION

All equipment should be carefully checked for damage or shortages as soon as it is received. Each shipment should be carefully checked against the bill of lading. If any damage or shortage is evident, a notation must be made on the delivery receipt before it is signed and a claim should then be filed against the freight carrier. **Inspection and claims are the responsibility of the recipient.**

1.2 LOSS OF GAS HOLDING CHARGE

The refrigeration coil section of each Levitor Series II unit is leak tested, evacuated to remove moisture and then shipped with a pressurized nitrogen gas holding charge. Absence of this charge may indicate a leak has developed in transit. The system should not be charged with refrigerant until it is verified that there is no leak, or the source of the leak is located and repaired if necessary.

2 MODELS AND DIMENSIONS

2.1 UNIT MODELS

Units are available with 24" and 30" diameter fans and a variety of motor speeds and horsepower's. All units are designed for vertical air discharge, with horizontal air discharge as an option. Each unit is constructed for the refrigerant and internal working pressure that is indicated on the unit nameplate. All units contain the UL, cUL, and CSA labels to indicate the unit was manufactured using acceptable practices by the governing bodies.

MODEL KEY:

L A V A - 2 4 4 10 M

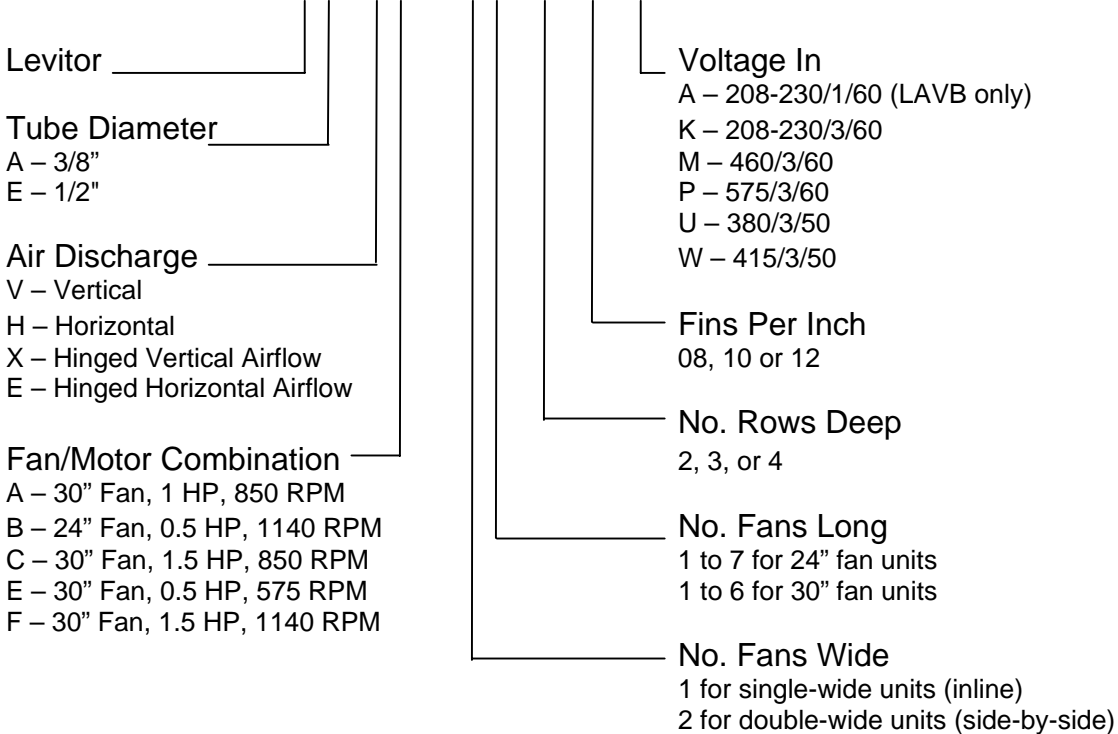

2.2 30" UNIT DIMENSIONS AND MOTOR AMPS

Figure 1 and Table 1 contain the overall dimensions, bolt hole locations, and motor amp draws for all of the 30" diameter fan units.

FIGURE 1 30" UNIT DRAWINGS

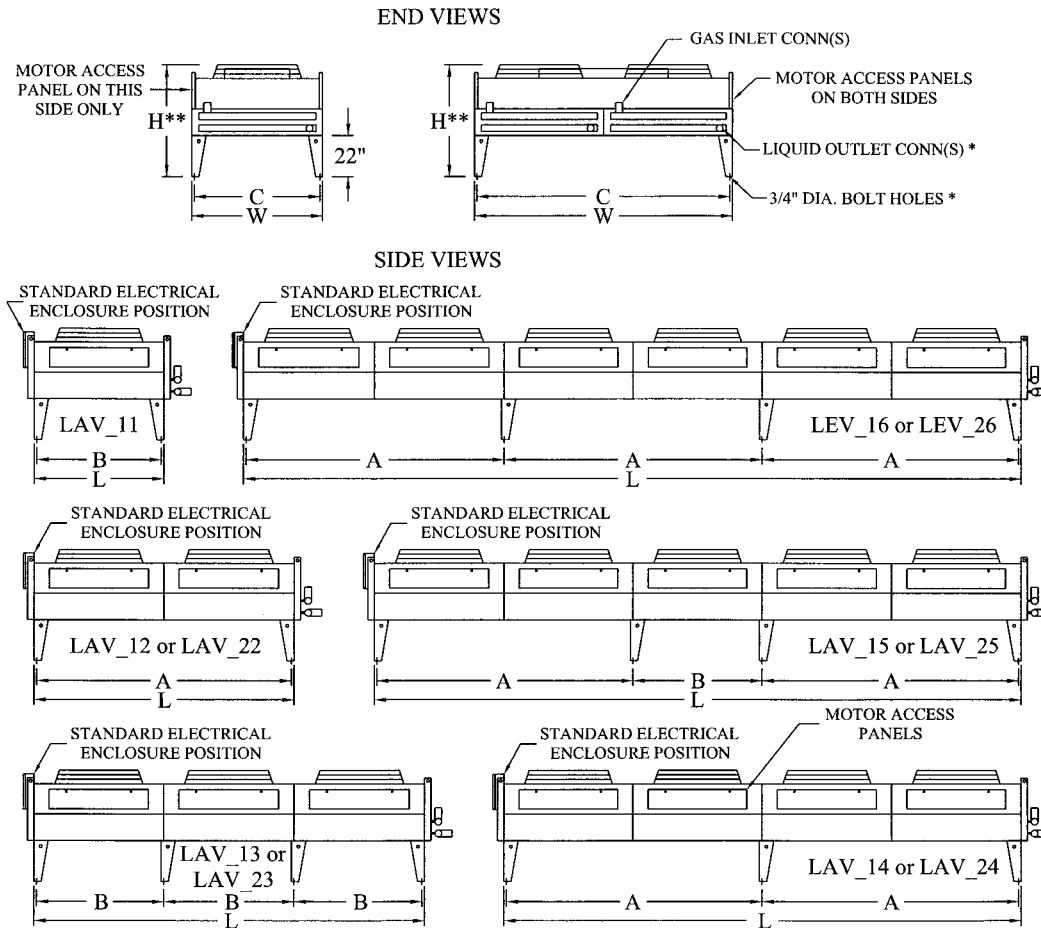

TABLE 1 30" UNIT DIMENSIONS

DIMENSIONS (inches)							DIMENSIONS (inches)						
MODEL	L	W	H**	A	B	C	MODEL	L	W	H**	A	B	C
LAV_11***	58	45.25	54	-	54	41.25	-	-	-	-	-	-	-
LAV_12***	112	45.25	54	108	-	41.25	LAV_22***	112	90.5	54	108	-	86.5
LAV_13***	166	45.25	54	108	54	41.25	LAV_23***	166	90.5	54	108	54	86.5
LAV_14***	220	45.25	54	108	-	41.25	LAV_24***	220	90.5	54	108	-	86.5
LAV_15***	274	45.25	58.5	108	54	41.25	LAV_25***	274	90.5	58.5	108	54	86.5
LEV_16***	328	45.25	58.5	108	-	41.25	LEV_26***	328	90.5	58.5	108	-	86.5

* - Connection size is determined by computerized circuiting program. See drawing with unit.

** - Includes standard 22" legs. Increase height accordingly if 30", 36", 42", 48", or 60" extended legs are used. If the 48" or 60" extended legs are used, every fan section down the length of the unit has a leg and gusset. 60" legs also have cross bracing. Legs, gussets, and bracing require field installation. See unit drawing for details.

*** - Rows & FPI

2.3 30" UNIT MOTOR AMPS

The following table contains the motor amps for the available fan motors.

TABLE 2 30" UNIT FULL LOAD MOTOR AMPS

MODEL	208/230/3/60	460/3/60	575/3/60	MODEL	208/230/3/60	460/3/60	575/3/60
ONE FAN WIDE 1 HP 850 RPM				TWO FANS WIDE 1 HP 850 RPM			
LAVA11***	4.4	2.0	1.5	-	-	-	-
LAVA12***	8.8	4.0	3.0	LAVA22***	17.6	8.0	6.0
LAVA13***	13.2	6.0	4.5	LAVA23***	26.4	12.0	9.0
LAVA14***	17.6	8.0	6.0	LAVA24***	35.2	16.0	12.0
LAVA15***	22.0	10.0	7.5	LAVA25***	44.0	20.0	15.0
LEVA16***	26.4	12.0	9.0	LEVA26***	52.8	24.0	18.0

ONE FAN WIDE 1.5 HP 850 RPM				TWO FANS WIDE 1.5 HP 850 RPM			
MODEL	208/230/3/60	460/3/60	575/3/60	MODEL	208/230/3/60	460/3/60	575/3/60
LAVC11***	6.0	3.0	2.5	-	-	-	-
LAVC12***	12.0	6.0	5.0	LAVC22***	24.0	12.0	10.0
LAVC13***	18.0	9.0	7.5	LAVC23***	36.0	18.0	15.0
LAVC14***	24.0	12.0	10.0	LAVC24***	48.0	24.0	20.0
LAVC15***	30.0	15.0	12.5	LAVC25***	60.0	30.0	25.0
LEVC16***	36.0	18.0	15.0	LEVC26***	72.0	36.0	30.0

ONE FAN WIDE 1/2 HP 575 RPM				TWO FANS WIDE 1/2 HP 575 RPM			
MODEL	208/230/3/60	460/3/60	575/3/60	MODEL	208/230/3/60	460/3/60	575/3/60
LAVE11***	3.4	1.7	1.2	-	-	-	-
LAVE12***	6.8	3.4	2.4	LAVE22***	13.6	6.8	4.8
LAVE13***	10.2	5.1	3.6	LAVE23***	20.4	10.2	7.2
LAVE14***	13.6	6.8	4.8	LAVE24***	27.2	13.6	9.6
LAVE15***	17.0	8.5	6.0	LAVE25***	34.0	17.0	12.0
LEVE16***	20.4	10.2	7.2	LEVE26***	40.8	20.4	14.4

ONE FAN WIDE 1.5 HP 1140 RPM				TWO FANS WIDE 1.5 HP 1140 RPM			
MODEL	208/230/3/60	460/3/60	575/3/60	MODEL	208/230/3/60	460/3/60	575/3/60
LAVF11***	7.0	3.5	2.4	-	-	-	-
LAVF12***	14.0	7.0	4.8	LAVF22***	28.0	14.0	9.6
LAVF13***	21.0	10.5	7.2	LAVF23***	42.0	21.0	14.4
LAVF14***	28.0	14.0	9.6	LAVF24***	56.0	28.0	19.2
LAVF15***	35.0	17.5	12.0	LAVF25***	70.0	35.0	24.0
LEV16***	42.0	21.0	14.4	LEV16***	84.0	42.0	28.8

*** - Model number shown does not include rows or fins per inch.

For unit Minimum unit Circuit Amps (MCA) and Maximum unit Overload Protection (MOP) consult the factory wiring diagram supplied with the unit.

2.4 30" UNIT WEIGHTS AND REFRIGERANT CHARGES

The following table contain approximate unit shipping weights and refrigerant charges for the 30" fan units. The Summer Charge is based on 25% of condenser volume with 86°F liquid. The Winter Charge is based on 90% of condenser volume with -20°F liquid.

TABLE 3 30" UNIT WEIGHTS AND REFRIGERANT CHARGES

UNIT	APPROX. WT. (LBS)	CONDENSER CHARGE (LBS)			
		R - 22		R - 404A	
		SUMMER	WINTER	SUMMER	WINTER
ONE FAN WIDE UNITS					
LAV_112**	445	4.3	20.2	3.8	18.4
LAV_113**	480	6.5	30.4	5.7	27.6
LAV_114**	510	8.6	40.5	7.5	36.8
LAV_122**	730	8.3	39.1	7.3	35.5
LAV_123**	790	12.4	58.6	10.9	53.3
LAV_124**	860	16.6	78.2	14.6	71.1
LAV_132**	1060	12.3	58.0	10.8	52.7
LAV_133**	1150	18.5	86.9	16.2	79.0
LAV_134**	1250	24.6	115.9	21.6	105.4
LAV_143**	1475	24.5	115.2	21.5	104.7
LAV_144**	1600	32.6	153.8	28.6	139.8
LAV_153**	2070	30.4	143.4	26.7	130.4
LAV_154**	2220	40.6	191.3	35.6	173.9
LEV_163**	2610	68.1	320.7	59.7	291.5
LEV_164**	2860	90.7	427.6	79.6	388.7
TWO FAN WIDE UNITS					
LAV_222**	1340	16.6	78.2	14.6	71.1
LAV_223**	1460	24.6	117.3	21.6	106.6
LAV_224**	1590	33.2	156.4	29.1	142.2
LAV_232**	1910	24.6	115.9	21.6	105.4
LAV_233**	2100	36.9	173.8	32.4	158.0
LAV_234**	2290	49.2	231.8	43.2	210.7
LAV_243**	2700	48.9	230.3	42.9	209.4
LAV_244**	2950	65.2	307.2	57.2	279.3
LAV_253**	3820	61.0	308.9	53.5	280.8
LAV_254**	4130	81.3	382.6	71.3	347.8
LEV_263**	4870	136.2	641.3	119.5	583.0
LEV_264**	5370	181.6	855.0	159.3	777.3

** - Fins per inch

_ - Motors A, C, E, or F

2.5 24" UNIT DIMENSIONS AND MOTOR AMPS

Figure 2 and Table 4 contain the overall dimensions, leg bolt hole locations, motor full load amps, and weights for all of the units with 24" diameter fans.

Figure 2 24" UNIT DIMENSIONS

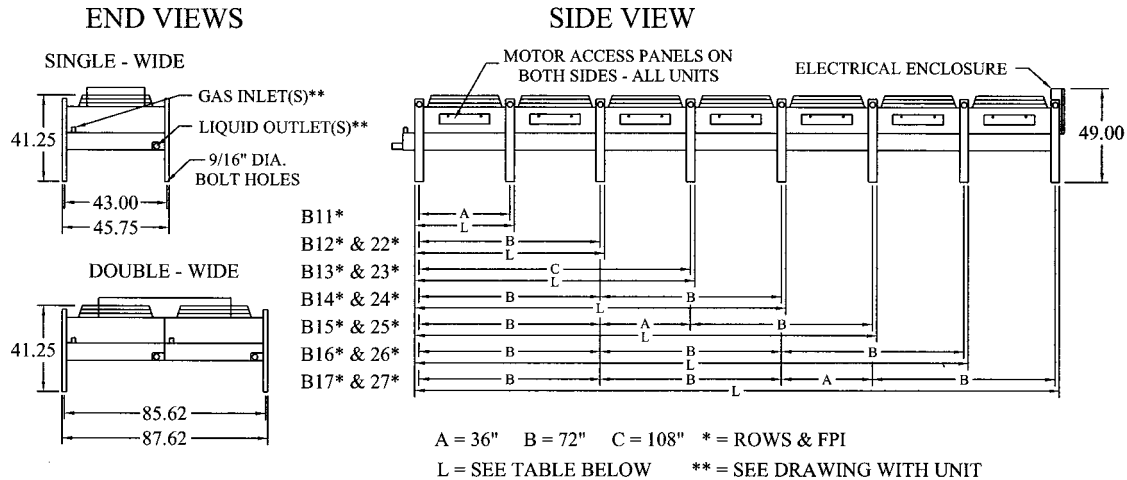

TABLE 4 24" UNIT DIMENSIONS, AMPS, AND WEIGHTS

UNIT	DIM. L	TOTAL MOTOR FULL LOAD AMPS (1)					(2) WINTER FLOOD CHARGE (LBS)(R-22)	WEIGHT INCL. FLOOD CHRG. (LBS)
		208/230/1	208-3	230-3	460-3	575-3		
ONE FAN WIDE UNITS								
LAVB11*	39	4.2	2.8	2.6	1.3	0.76	19	180
LAVB12*	75	8.4	5.6	5.2	2.6	1.52	39	360
LAVB13*	111	12.6	8.4	7.8	3.9	2.28	58	540
LAVB14*	147	16.8	11.2	10.4	5.2	3.04	86	720
LAVB15*	183	21.0	14.0	13.0	6.5	3.80	97	900
LAVB16*	219	25.2	16.8	15.6	7.8	4.56	116	1080
LAVB17*	262	29.4	19.6	18.2	9.1	5.32	144	1260
TWO FAN WIDE UNITS								
-	-	-	-	-	-	-	-	-
LAVB22*	75	16.8	11.2	10.4	5.2	3.04	86	700
LAVB23*	111	25.2	16.8	15.6	7.8	4.56	116	1050
LAVB24*	147	33.6	22.4	20.8	10.4	6.08	172	1400
LAVB25*	183	42.0	28.0	26.0	13.0	7.60	194	1750
LAVB26*	219	50.4	33.6	31.2	15.6	9.12	232	2100
LAVB27*	262	58.8	39.2	36.4	18.2	10.64	288	2450

* - Model number shown does not include rows or fins per inch.

(1) For unit Minimum unit Circuit Amps (MCA) and Maximum unit Overload Protection (MOP) consult the factory wiring diagram supplied with the unit.

(2) Values listed are for 4 Row units. For 3 Row units multiply by 0.75. For 2 Row units multiply by 0.5.

3 UNIT LOCATION

The Levitor Series II units require adequate space to allow unrestricted ambient airflow in to and out of the fan section. Figure 3 gives general rules of the location of an air-cooled condenser in different situations. The distances shown in the sketches should be increased whenever possible. The unit position relative to the prevailing winds should be taken into account. Note that higher than expected head pressures will result in poor system operation if the following suggested distances are not used.

So that the unit performs as predicted it should be located away from heated air exhausts, steam vents, or corrosive airflow, whether it comes from the job site, or from another nearby source. A corrosive atmosphere will require an appropriate coil coating, or copper fins to protect the coil and extend the life of the unit.

Unit location with regard to noise should also be considered. An air-cooled condensing unit should be located away from noise and vibration sensitive spaces to avoid transmission into workspaces.

Figure 3 LOCATION REQUIREMENTS

Walls or Barriers

For proper airflow and access, all sides of the unit should be a minimum of "W" away from any wall or barrier. Enough space should be allowed for all maintenance work. Overhead obstructions are not allowed.

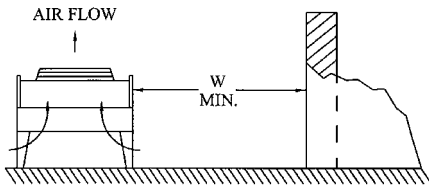

Multiple Units

For units placed side by side, the minimum distance between units is the width of the largest unit. If units are placed end to end, the minimum distance between units is one fan section long.

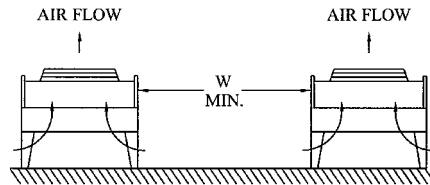

Walls or Barriers for Horizontal Airflow

Units with horizontal airflow should be a minimum of "W" away from any wall or barrier, plus the air discharge should be free flowing away from the unit.

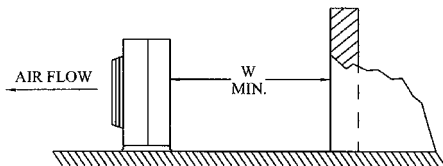

Decorative Fences

Fences must have 50% free area, with 1 foot undercut, a "W" minimum clearance, and must not exceed the top of the unit.

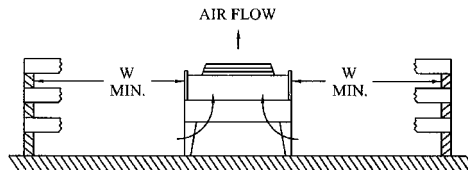

W = Total width of the air-cooled condensing unit.

4 RIGGING

The Levitor Series II units are designed to be lifted using the leg support channels or the side lifting brackets for larger units. The unit mounting leg assemblies are best attached when the unit is in the flat, fans facing up, and supported by the rigging. Take special care not to bump, hit, or otherwise stress the tubing, headers, or connections during the lifting and positioning of the unit. Under no circumstances should the coil headers or return bends be used in lifting or moving the unit. See Figures 4, 5, and 6 for the designated lifting points and lift methods for all unit sizes, plus approximate unit weights.

FIGURE 4 RIGGING FOR 30" FAN UNITS

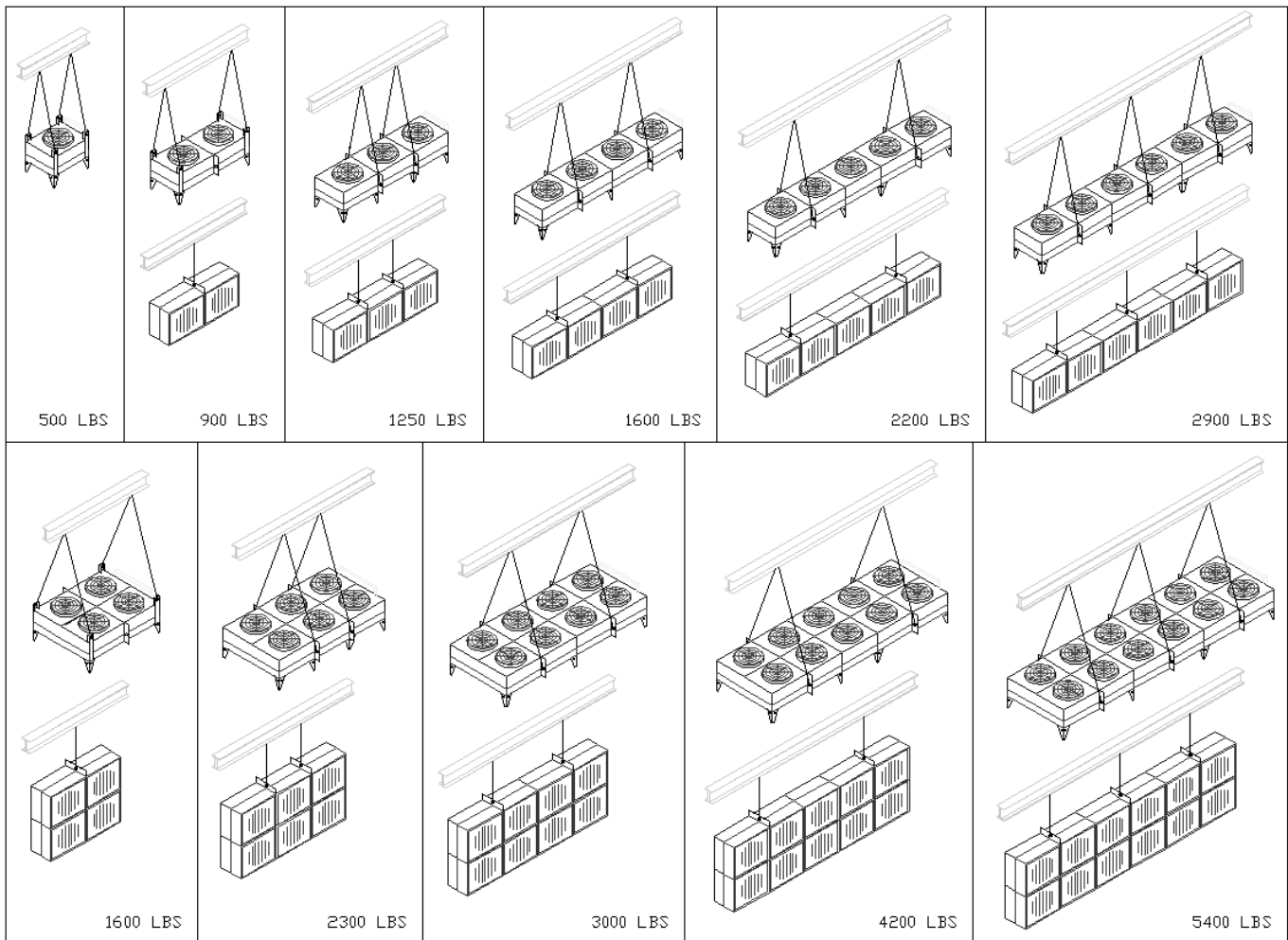

STATIONARY LIFTING POINTS AND LIFTING PLATES FACTORY MOUNTED. OUTER SUPPORT LEGS (IF REQUIRED) SHIPPED LOOSE FOR FIELD INSTALLATION BY OTHERS WITH NECESSARY BOLTS, WASHERS AND NUTS INCLUDED, (SEE SECTION 5.1 FOR LEG MOUNTING INSTRUCTIONS). UNDER NO CIRCUMSTANCES SHOULD CONSIDER MANIFOLDS, ELECTRICAL ENCLOSURE(S) OR RETURN BENDS BE USE FOR LIFTING OR MOVING THE UNITS!

FIGURE 5 RIGGING FOR 30" FAN UNITS WITH RECEIVERS

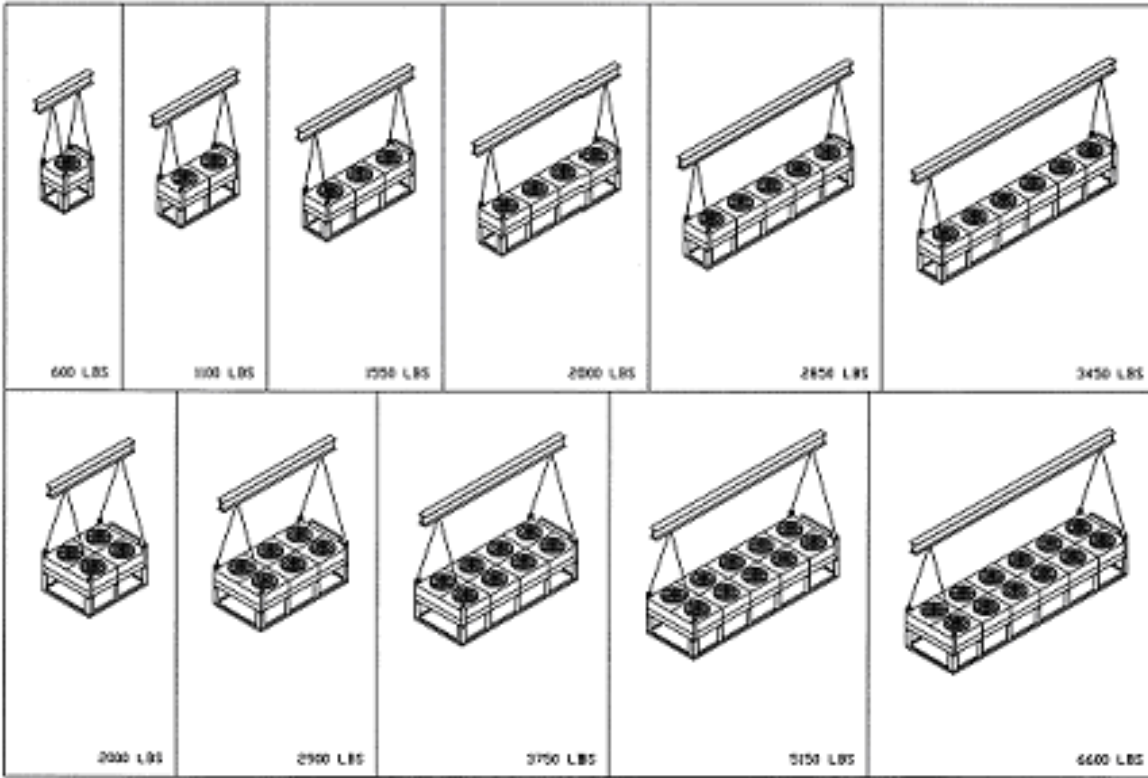

STATIONARY LIFTING POINTS AND LIFTING PLATES FACTORY MOUNTED. OUTER SUPPORT LEGS HAVE ADDITIONAL LIFTING HOLES, BUT A SPREADER MUST BE USED TO PREVENT SHEETMETAL DAMAGE. UNDER NO CIRCUMSTANCES SHOULD CONSIDER MANIFOLDS, ELECTRICAL ENCLOSURE(S) OR RETURN BENDS BE USE FOR LIFTING OR MOVING THE UNITS!

FIGURE 6 RIGGING FOR 24" FAN UNITS

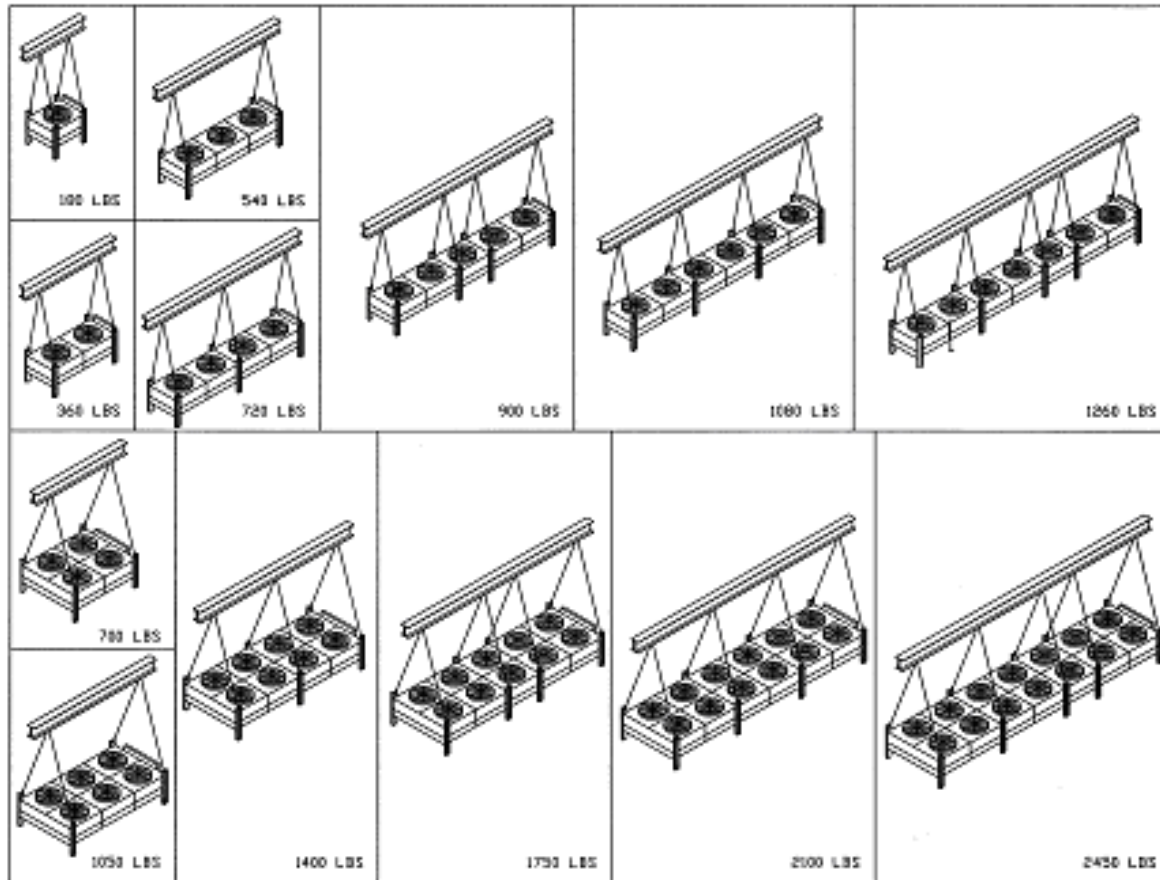

STATIONARY LIFTING POINTS AND LIFTING PLATES FACTORY MOUNTED. OUTER SUPPORT LEGS (IF REQUIRED) SHIPPED LOOSE FOR FIELD INSTALLATION BY OTHERS WITH NECESSARY BOLTS, WASHERS AND NUTS INCLUDED, (SEE SECTION 5.1 FOR LEG MOUNTING INSTRUCTIONS). UNDER NO CIRCUMSTANCES SHOULD CONSIDER MANIFOLDS, ELECTRICAL ENCLOSURE(S) OR RETURN BENDS BE USE FOR LIFTING OR MOVING THE UNITS!

5 UNIT ASSEMBLY

5.1 LEG ASSEMBLY FOR 30" FAN UNITS

For Levitor Series II units with 30" diameter fans that will blow air in a vertical direction, the unit is supported by formed, mill galvanized, channel legs that provide a standard 22" of clearance from the bottom of the leg to the bottom of the coil section. Install the legs on the unit before rigging the unit into place with the hardware provided with the unit. If extended legs are ordered to provide additional clearance, the leg attachment is the same as the standard leg. Support legs that are 48" or 60" in height will require a leg between every fan section and gusset for stability. 60" legs also require cross bracing, see drawing provided with unit for details.

FIGURE 7 STANDARD 22" & 42" LEG ASSEMBLY

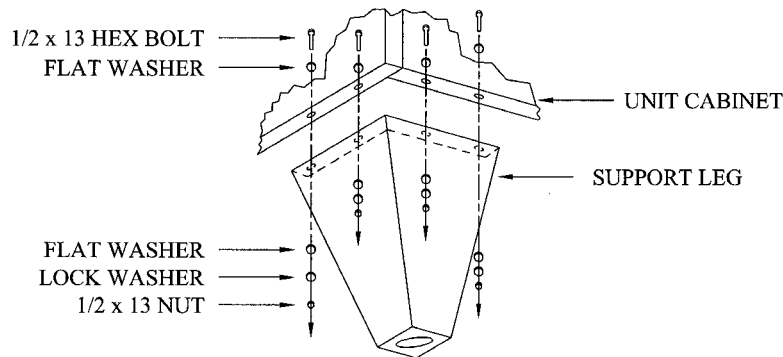

5.2 OPTIONAL GRAVITY DAMPERS FOR 30" FAN UNITS

For Levitor Series II units with 30" diameter fans that have been ordered with Gravity Dampers, the dampers are shipped assembled to the unit, but the airflow extensions must be raised from the shipping position. Before working on the outer extensions, remove and discard the small hold down brackets that have secured the damper blades during shipping. The extension for each fan is held onto the gravity damper assembly by (8) #14 hex head screws 1/2" long. Remove the eight screws from each extension, raise the extension so that the screw holes in the bottom of the extension match the bolt holes in the top of the damper assembly, and assemble the screws tightly. See Figure 8 for the extension in both the shipping and raised positions.

FIGURE 8 GRAVITY DAMPER ASSEMBLY

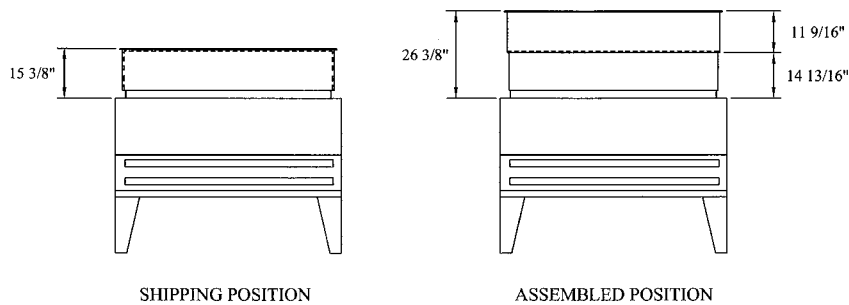

5.3 HORIZONTAL AIRFLOW BASE SUPPORT

For 30" fan Levitor Series II units ordered with a horizontal airflow base supports are attached to the unit at the factory. Caution should be taken when raising and moving the unit so that the supports are not bent. Double-wide fan units require field mounting of an angle support brace shipped loose with the unit. See drawing send with the unit for mounting details.

5.4 LEG ASSEMBLY FOR 24" FAN UNITS

For Levitor Series II units with 24" diameter fans blowing air in a vertical up direction, the unit is supported by formed, mill galvanized, channel legs that provide a standard 18" of clearance from the bottom of the leg to the bottom of the coil section. The standard 18" legs are factory mounted to the unit. If extended legs are ordered, to provide 42" of clearance, the attachment procedure for the shipped loose legs and the cross bracing is shown in Figure 9 below. Raise the unit off the ground via rigging or other stable support for leg and bracing attachment.

Units that are designed to blow air in the horizontal direction do not require legs and are ready to be rigged into position.

FIGURE 9 42" LEG & BRACING ASSEMBLY FOR 24" FAN UNITS

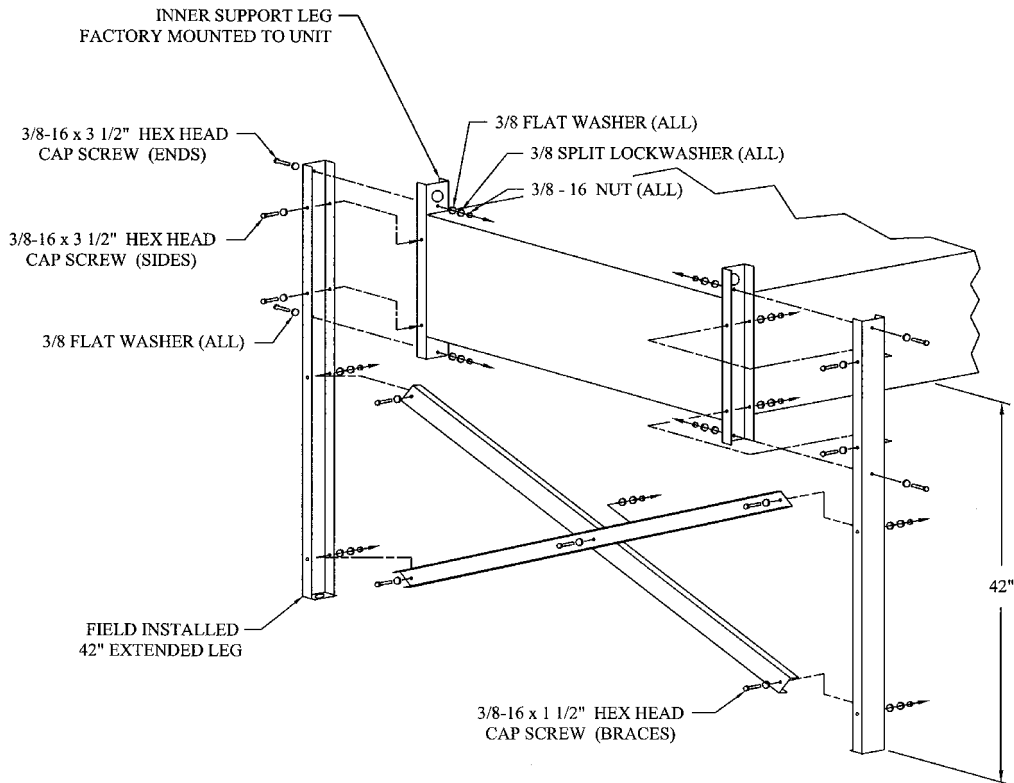

6 INSTALLATION AND PIPING

6.1 MOUNTING THE UNIT

The unit must be installed on a firm, level base to assure optimum unit performance. The mounting legs should be securely fastened at their base to the steel or concrete of the supporting base. For roof mounted installations, the steel supporting base holding the unit should be elevated above the roof and fastened to the columns or load bearing walls of the building. See Figure 9 for mounting examples.

6.2 INTERCONNECTING PIPING FOR DOUBLE WIDE UNITS

Interconnecting refrigerant piping for double wide units should be as short and as direct as possible to the unit header connections. The gas inlet piping should always down-feed into the units' inlet header and be equipped at its highest point with a pressure tap (purge) type valve. Liquid outlet piping is to be directed immediately downwards in a minimum 15" drop leg, making a liquid seal. The drop leg is to be before making any bends or angles connecting it to the remainder of the liquid connection piping run. If the header sheet metal covers were removed for piping, replace the covers for header and return bend protection. See Figure 10 for suggested interconnecting piping support arrangements.

6.3 REFRIGERATION PIPING

All jobsite refrigeration piping connecting the condenser should conform to the applicable local and state codes as well as to the latest ASIB B9.1 and B31.5 standards. Use the proper pipe sizes for the installation. Follow good commercial piping practices throughout the installation, which includes properly bracing the lines.

AC&R type copper tubing should be used throughout. Cut tubing with a wheel-type cutter and not a hacksaw. Debur before assembly in the fittings. NOTE: if the on site tubing lengths to be used were not capped (i.e., are not perfectly clean) they should be dragged internally with a clean, lint-free rag before fabricating into the system. Soft solders are not to be used. Always clean all pipe and fitting areas that will be brazed with the proper grade emery cloth. Plan to use only oxy-acetylene brazing. A higher content silver brazing rod must be used to avoid excessive use of flux, less it be pushed into the system piping, which will create problems at a later date. Use a silver solder which contains sufficient silver content necessary for joint strength and flexibility, yet requires minimum use of flux. For copper-to-copper joints, use a phos-copper solder with 15% silver content. Some easy-flow types require no flux, and the resultant joints are of maximum strength without brittleness. Nitrogen should be used to purge the air from the connecting tubing during brazing in order to prevent copper oxide formations.

A pressure tap valve should be installed at the highest point in the condenser inlet piping run so as to facilitate the removal of inadvertently trapped non-condensable gases from the system. The purging process should only be done with the compressor system off and pressures equalized. Do not endeavor to do this unless you are qualified and have the proper reclaim/recovery equipment mandated by the EPA.

Consideration should be given that under sizing connecting lines will cause a number of problems in a refrigeration system. High pressure drop in the discharge line takes away from the systems capacity as well as resulting in excessive power usage.

Sizing a discharge line too large will inhibit compressor lube oil circulation. The proper balance is to design discharge lines for approximately 4000 ft/min velocity in vertical risers, and can be lowered to 2000 ft/min in sloped horizontal runs. "P" traps should be installed at the base of all vertical discharge riser lines to facilitate proper oil return to the compressor. This is especially true immediately downstream of the compressor in order to prevent refrigerant liquid and/or oil migrating back into the compressor heads when the compressor is not running.

FIGURE 10 UNIT MOUNTING AND PIPING

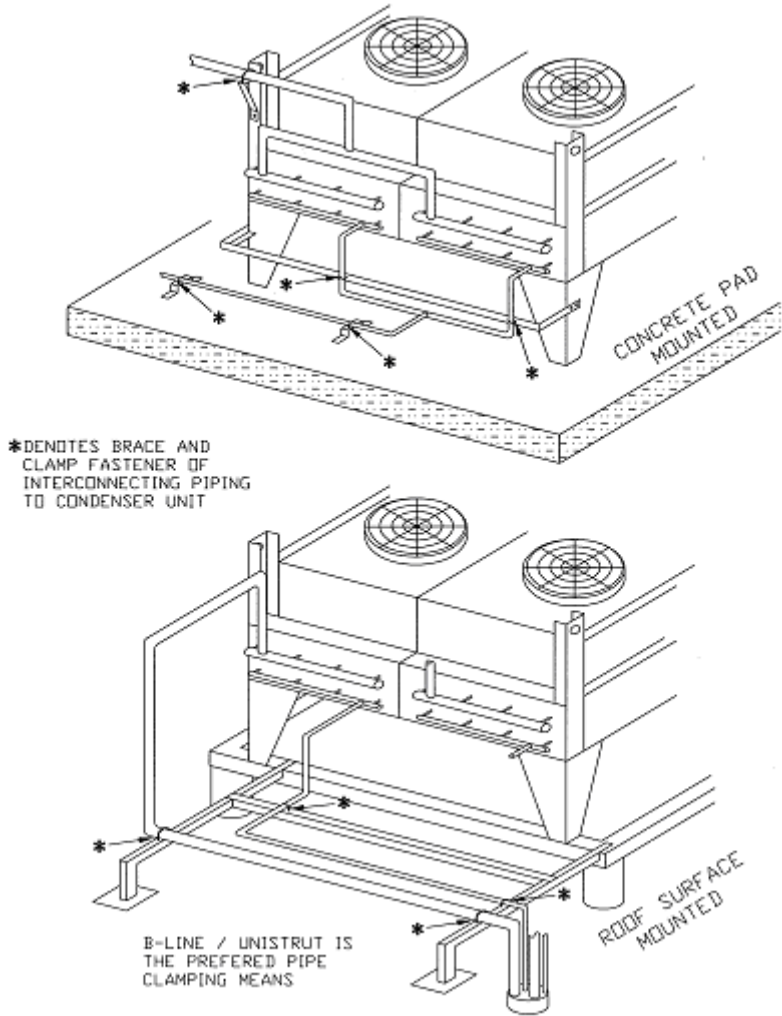

High pressure drop in the liquid line can result in the complete reduction of the liquid subcooling, thus causing flash gas at the expansion valve. Coil starving and reduced capacity will be the result. Liquid lines can also be misapplied if sized too large. The sizing affects the oil-to-refrigerant mixture ratio as well as necessitating charging the system with an excessive amount of refrigerant. Proper sizing of both the discharge and liquid lines is a necessity for a properly working system. Table 5 is a guide for line sizing.

TABLE 5 24" REFRIGERANT LINE SIZING

COPPER LINE SIZE O.D.	LINE CAPACITY IN TONS						COND. TO RECIEVER LIQUID LINE			LBS OF REFRIG. LIQUID PER 100' OF LINE LENGTH		
	COMPRESSOR DISCHARGE LINE											
	R22		R404A		R134A		R22	R404A	R134A	R22	R404A	R134A
	100'	200'	100'	200'	100'	200'						
5/8	1.5	1.0	1.0	0.5	1.0	0.5	3.6	3	3.7	13	11	13
7/8	4	3	3	2	3	2	7.4	6	7.7	25	22	26
1 1/8	10	6.5	7	4	6.5	4.5	12.7	10.4	13	42	36	43
1 3/8	20	15	15	7	12	7	19.2	16	20	64	55	65
1 5/8	30	20	20	15	20	11	29	23	28.5	90	78	92
2 1/8	65	45	45	30	42	28	47	40	46	160	138	163
2 5/8	90	75	75	45	55	43	73	62	72	245	212	250

Capacity is compressor suction tons for application between -40°F and +40°F suction at condensing between 80°F and 120°F saturation. For multiple, or unloading compressor applications, the vertical discharge riser from the compressor may need to be one size smaller. The table data is only to be used as a guide. For exact values, calculate your specific line lengths and design pressure/temperature values using the ASHRAE handbook or ARI refrigerant tables.

Generally, horizontal piping runs should grade slightly downwards in the direction of flow. Liquid line piping must be arranged so that it is free draining from the condenser to the receiver. It is best to pipe liquid lines so that there is an immediate drop of 2 to 3 feet at the condenser outlet before any field headering or horizontal run. The liquid line must be free of any traps or loops and constantly be pitched downhill towards the receiver. Avoid long horizontal lines on roofs. The liquid line is to be sized so the velocity does not exceed 100 feet per minute. Where the ambient temperature can be below the equipment room temperature, a check valve must be installed in the liquid line to prevent liquid migration at the condenser.

Provisions must be made to accommodate expansion and contraction of the lines, especially if the lines have long runs with few elbows or bends. The lines must also be adequately supported at frequent intervals in accordance with good piping practice. It is necessary that field bracing provide adequate support at the condenser connections. See Figure 10 for suggested arrangements.

Special precautions must be taken if the refrigeration system is a multiple parallel and/or the condenser is mounted substantially higher than the compressor unit. A double riser discharge line should be used as shown in Figure 11. Such arrangement is necessary to facilitate compressor lube oil return to the compressor crankcase.

Pressure testing of the piping should be done as soon as the field piping has been completed. The high-side test pressure should not exceed the condenser unit UL nameplated pressure. Nitrogen may be used to increase the trace refrigerant pressure for leak testing. It is recommended that an electronic type leak tester be used. Shipping vibrations can stress joints, thus producing operating leaks which would otherwise go undetected from just a low pressure holding charge. Therefore, check for leaks at all joints, field and factory, before charging the system.

NOTE: If automatic isolating valves are used to shut down half of the condenser during winter operation, precautions must be employed to eliminate hydraulic shock when the valves are opened for warmer weather operation. This supplementary valving must not be supported from or by the condenser header(s).

FIGURE 11 DOUBLE RISER DISCHARGE ARRANGEMENT

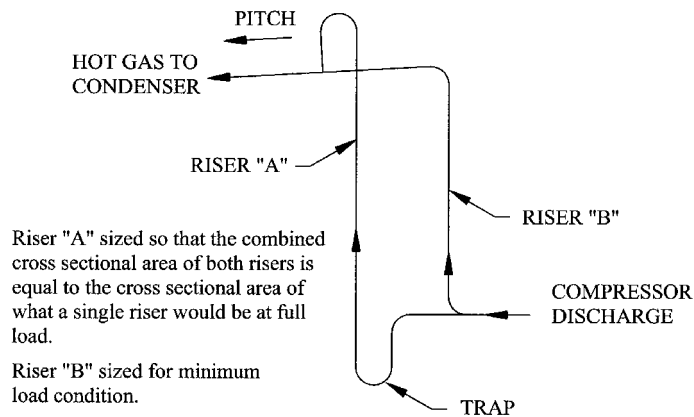

6.4 HOLDBACK FLOODING CONTROL

Figure 12 shows typical piping drawings for flooding control arrangements of Levitor Series II condensers.

Figure 12 HOLDBACK FLOODING CONTROL ARRANGEMENTS

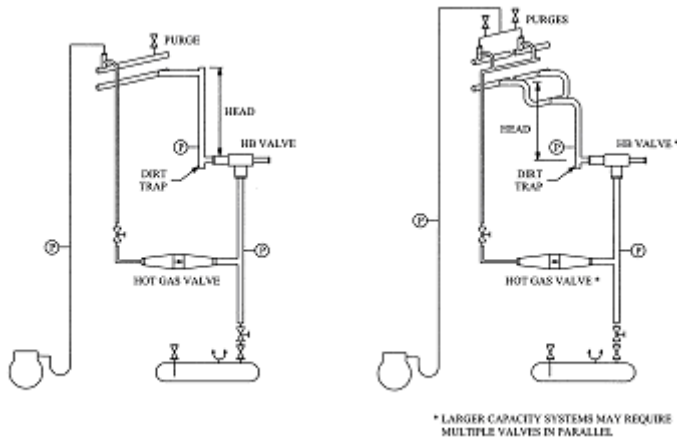

7 ELECTRICAL

If the Levitor Series II unit is equipped with an electrical power disconnect switch make sure the switch is in the "OFF" position, preferably locked in this position, before any electrical work is performed to the unit.

The Levitor Series II unit can be arranged at the factory so that each motor is wired to individual terminal blocks, in which case each motor requires individual power wiring, or the motors can be wired to a fan cycling control panel which requires only one set of power wires. The fan cycling control panel can consist of a series of pressure/temperature controllers or a printed circuit board. See the electrical drawing that accompanies the unit for details.

Check fan blade clearances within the venturies so that each fan is horizontally centered in the venturi. Fan motors operating at higher elevations will draw lower than rated amps, as well as draw a less effective air volume across the coil surface. This is due to the reduced density of the higher altitude air resulting in higher compressor discharge pressure along with reduced unit capacity. Consult factory if you suspect this situation.

7.1 FIELD WIRING

Field wiring should comply with NEC and local codes. The power supply voltage, phase, and frequency must match what is shown on the unit data plate. Only qualified electricians should work on the electrical portion of any unit installation.

7.2 MOTORS WIRED TO TERMINAL BLOCKS

Figure 13 are typical unit wirings to terminal blocks. Fan motors are turned on and off by controls outside of the unit and by others.

FIGURE 13 TERMINAL BLOCK ONLY WIRING DIAGRAMS (NC - C444)

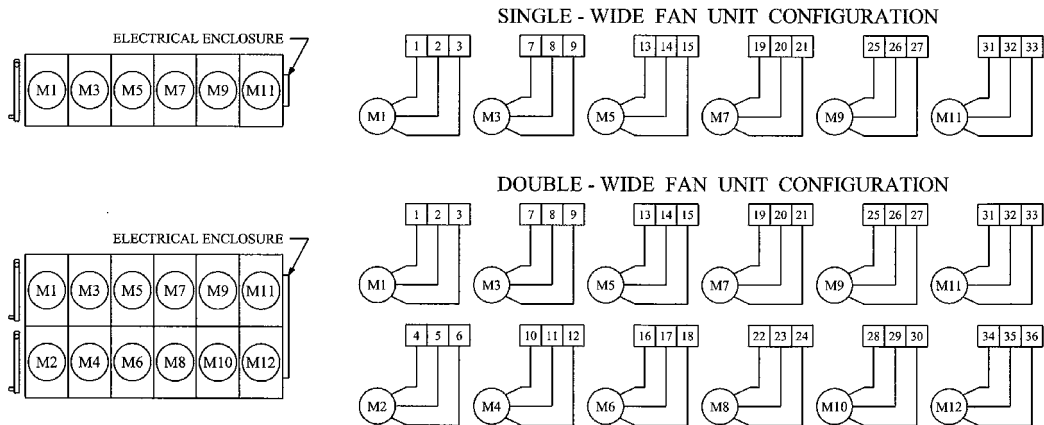

7.3 MOTORS WIRED TO STANDARD FAN CYCLING CONTROL PANEL

The standard fan cycling control panel for Levitor Series II units contains a series of pressure or temperature controllers. The fans cycle on and off from the signal by the pressure or temperature sensor. If the unit has one row of fans the fan cycling controls turn the fans on or off individually. If the unit has two rows of fans, either adjoining pairs of fans or individual fans can be cycled depending upon the system requirements. The fan(s) nearest the headers are the first-on, last-off, and are continuously on when the compressor is running. Figures 14 and 15 have typical wiring schematics.

FIGURE 14 INDIVIDUAL FAN MOTOR CYCLING WIRING DIAGRAM (-311)

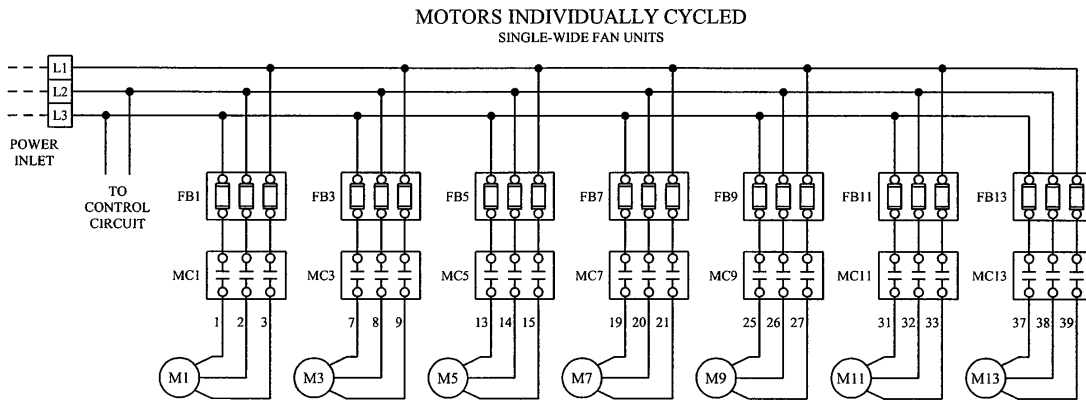
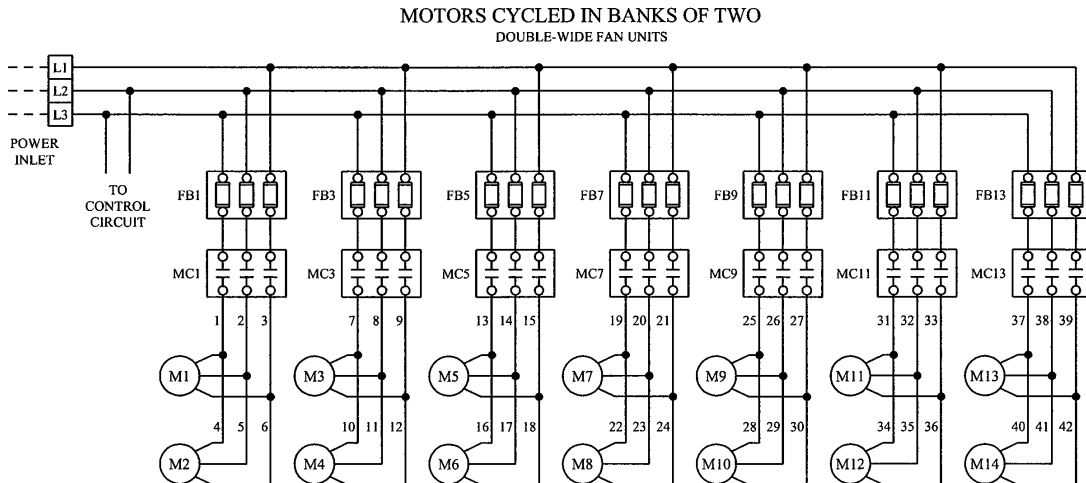

FIGURE 15 FAN MOTOR CYCLING IN PAIRS WIRING DIAGRAM (-331)



7.4 FAN CYCLE OPERATION

The operation of the fan cycle controller employed with the Levitor Series II condenser should be set up so that the fan, or set of fans if a double wide unit, nearest the unit headers is/are in continuous operation whenever a system compressor is running.

Not complying with this condition can cause uneven rapid expansion and contraction of the condenser core tubing, contributing to condenser tube failures. Violation of this condition is most often associated with electronic controllers and must be avoided through correct programming. This also means do not program the "header end" fans(s) for "equal run time".

The excessive tube stress within the condenser, due to rapid expansion and contraction of the coil, is caused by needless temperature swings, which result from incorrect fan cycling during cold weather. The header end fan(s) will desuperheat the entering hot gas and allow the remaining condenser surface to condense the refrigerant at internal temperatures that are not a threat to the performance of the equipment.

Due to the Levitor coil support system, all fans may be cycled without increasing the risk of condenser tube failures. To obtain the maximum life from the condenser, as well as meet with warranty stipulations, the following field set-up is required:

1. Always set the header end fan(s) to cycle as first-on, last-off in the fan cycle scheme.
2. Do not set the fans to cycle-on more than 30 times per hour, or lower than a minimum of 40 PSI discharge pressure differential swing. The maximum short cycling is one minute on, one minute off.

7.5 CONTROL SETTINGS

Tables 6 & 7 contain the settings to which the control panel components are set for the ordered application. Table 6 contains the settings for pressure sensing controls and Table 7 contains the settings for temperature setting controls. If a type of control other than the Johnson 350 series controller is used, such as a printed circuit board or variable speed, consult the wiring schematic for the unit ordered.

7.6 TEMPERATURE SENSOR

For units that use a temperature sensor as input into the fan controls, the sensor will be factory wired but shipped inside the control panel to prevent damage during transportation. Once the unit is mounted in the final position open the control panel, unroll the temperature sensor wire and field mount the sensor in the inlet air stream 3+ inches away from the fin pack.

TABLE 6 CONTROL PANEL SETTINGS – PRESSURE SENSING

		PRESSURE CONTROL PRESSURE SETTINGS (PSIG) (R-22)							PRESSURE CONTROL PRESSURE SETTINGS (PSIG) (R-404a)						
PRESSURE CONTROL #		---	PC2	PC3	PC4	PC5	PC6	PC7	---	PC2	PC3	PC4	PC5	PC6	PC7
FAN MOTOR CONTACTOR NUMBER	Single Wide Units	MC1	MC3	MC5	MC7	MC9	MC11	MC13	MC1	MC3	MC5	MC7	MC9	MC11	MC13
	Double Wide Units	MC1 & MC2	MC3 & MC4	MC5 & MC6	MC7 & MC8	MC9 & MC10	MC11 & MC12	MC13 & MC14	MC1 & MC2	MC3 & MC4	MC5 & MC6	MC7 & MC8	MC9 & MC10	MC11 & MC12	MC13 & MC14
SET OFFSET	F	200							F	240					
DIFF	A	--							A	--					
FAN ON	N	40							N	40					
FAN OFF	(S)	200							(S)	240					
SET OFFSET	R	10	210						R	10	250				
DIFF	U	--	--						U	--	--				
FAN ON	N	40	40						N	40	40				
FAN OFF		200	210							240	250				
		160	170							200	210				
SET OFFSET	W	--	--	215					W	--	--	260			
DIFF	I	15	10	--					I	20	10	--			
FAN ON	T	40	40	40					H	40	40	40			
FAN OFF	H	200	205	215						240	250	260			
		160	165	175						200	210	220			
SET OFFSET	A	--	--	--	220				A	--	--	--	265		
DIFF	N	20	15	10	--				N	25	15	5	--		
FAN ON	Y	40	40	40	40				Y	40	40	40	40		
FAN OFF		200	205	210	220					240	250	260	265		
		160	165	170	180					200	210	220	225		
SET OFFSET	C	--	--	--	--	225			C	--	--	--	--	270	
DIFF	O	25	20	15	10	--			O	30	20	10	5	--	
FAN ON	M	40	40	40	40	40			M	40	40	40	40	40	
FAN OFF	P	200	205	210	215	225			P	240	250	260	265	270	
	R	160	165	170	175	185				200	210	220	225	230	
SET OFFSET	S	--	--	--	--	--	225		S	--	--	--	--	--	270
DIFF	S	30	25	20	15	10	--		O	40	30	20	10	5	--
FAN ON	O	40	40	40	40	40	40		R	40	40	40	40	40	40
FAN OFF	R	195	200	205	210	215	225			230	240	250	260	265	270
		155	160	165	170	175	185			190	200	210	220	225	230

NOTE: MOTOR CONTACTORS WIRED TO “NC” CONTACT OF PRESSURE CONTROL.
PRESSURE CONTROL SET IN “REVERSE” MODE. SEE WIRING DIAGRAM IN UNIT CONTROL PANEL.

TABLE 7 CONTROL PANEL SETTINGS – TEMPERATURE SENSING

		AMBIENT CONTROL TEMPERATURE SETTINGS (°F)						
TEMPERATURE CONTROL #		---	TC2	TC3	TC4	TC5	TC6	TC7
FAN MOTOR CONTACTOR NUMBER	Single Wide Units	MC1	MC3	MC5	MC7	MC9	MC11	MC13
	Double Wide Units	MC1 & MC2	MC3 & MC4	MC5 & MC6	MC7 & MC8	MC9 & MC10	MC11 & MC12	MC13 & MC14
SET OFFSET DIFF FAN ON FAN OFF		FAN (S)	60 -- 20 60 40					
SET OFFSET DIFF FAN ON FAN OFF		RUN	-- 10 10 55 45	65 -- 15 65 50				
SET OFFSET DIFF FAN ON FAN OFF		WITH	-- 15 10 55 45	-- 10 10 60 55	70 -- 5 70 65			
SET OFFSET DIFF FAN ON FAN OFF		ANY	-- 20 10 55 45	-- 15 5 60 55	-- 5 5 70 65	75 -- 5 75 70		
SET OFFSET DIFF FAN ON FAN OFF		COMPRESSOR	-- 25 5 55 45	-- 20 5 60 55	-- 15 5 65 60	-- 10 5 70 65	80 -- 5 80 75	
SET OFFSET DIFF FAN ON FAN OFF		SOR	-- 25 10 55 45	-- 20 5 60 55	-- 15 5 65 60	-- 10 5 70 65	-- 5 5 75 70	80 -- 5 80 75

NOTE: MOTOR CONTACTORS WIRED TO “NC” CONTACT OF TEMPERATURE CONTROL.
TEMPERATURE CONTROL SET IN “HEATING” MODE. SEE WIRING DIAGRAM IN UNIT CONTROL PANEL.

8 INSPECTION AND CLEANING

If the Levitor Series II unit is equipped with an electrical power disconnect switch make sure the switch is in the "OFF" position, preferably locked in this position, before any electrical work is performed on the unit. Without a disconnect switch on the unit, make sure all power to the unit is off from the source.

Electrical connections should be inspected periodically and tightened if required. Loose electric connections can cause severe electrical damage as well as nuisance tripout and burnouts.

During the unit start up phase check the fans for the correct rotation. While the fans are rotating the airflow should pass through the coil surface first, flow through the fan and away from the unit. If the fans are pushing the air into the coil surface the fans are rotating in the wrong direction and the motor wiring needs to be corrected.

For maximum efficiency, air-cooled condensers should be cleaned of lint and dust every 4 to 6 months so that airflow is not restricted. More frequent cleaning may be necessary under severe conditions. Use a water spray with an approved cleaning solution for finned tube coils, such as those used on air conditioning units. The water and cleaning solution should be sprayed on the coil surface opposite the direction of the fan airflow direction. The Levitor Series II units are equipped with convenient access panels to allow the cleaning spray wand to be inserted into the fan cabinet above the coil section and below each motor & fan.

9 REPLACEMENT PARTS LISTS

TABLE 8 TYPICAL REPLACEMENT PART NUMBERS

ITEM	PART NO.
L_VA UNIT	
MOTOR: 1 HP 850 RPM 208-230/460/3/60	11503
1 HP 850 RPM 575/3/60	E205307
FAN: 30" DIA. CW 5/8" BORE	11273
GUARD: FOR 30" FAN	E280792
LAVB UNIT	
MOTOR: 1/2 HP 1140 RPM 208-230/460/3/60	11525
1/2 HP 1140 RPM 575/3/60	CALL
FAN: 24" DIA. CCW 5/8" BORE	E206876
GUARD: FOR 24" FAN	E82691
L_VC UNIT	
MOTOR: 1 1/2 HP 850 RPM 208-230/460/3/60	E151976
1 1/2HP 850 RPM 575/3/60	E151976A
FAN: 30" DIA. CW 5/8" BORE	E151977
GUARD: FOR 30" FAN	E280792
L_VE UNIT	
MOTOR: 1/2 HP 575 RPM 208-230/460/3/60	E206880
1/2 HP 575 RPM 575/3/60	E318680
FAN: 30" DIA. CW 5/8" BORE	E205493
GUARD: FOR 30" FAN	E280792
L_VF UNIT	
MOTOR: 1 1/2 HP 1140 RPM 208-230/460/3/60	E205492
1 1/2 HP 1140 RPM 575/3/60	E206689
FAN: 30" DIA. CW 5/8" BORE	E205493
GUARD: FOR 30" FAN	E280792

TABLE 9 MISCELLANIOUS REPLACEMENT PART NUMBERS

1/2 HP 208-230/1/60 FOR VARIABLE SPEED	E205529
3/4 HP 208-230/1/60 FOR VARIABLE SPEED	E205530
MOTOR CONTACTOR w/24 VOLT COIL	E150076
MOTOR CONTACTOR w/110 VOLT COIL	10748
MOTOR CONTACTOR w/230 VOLT COIL	E205170
P352AB-3C PRESSURE CONTROLLER	E207051
S352AA-2C ADDER MODULE (PRESSURE)	E207052
P399BAC-1C PRESSURE TRANSDUCER	E207053
A350AB-1 TEMPERATURE CONTROLLER	E205533
Y350 R-1 POWER MODULE	E205534
S350AA-1 ADDER MODULE (TEMPERATURE)	E205535
A99BC-300 TEMPERATURE SENSOR (9.75 FEET)	E205564
MOTOR MOUNT FOR 24" FAN UNIT (1 PER MOTOR)	82039
MOTOR MTG BRACKET FOR 30" FAN UNIT (2 PER MOTOR)	E280793
MOTOR MTG RING FOR 30" FAN UNIT (1 PER MOTOR)	80034
STD 18" SUPPORT LEG FOR 24" FAN UNIT	E281661
STD 22" TAPERED SUPPORT LEG FOR 30" FAN UNIT	80084
SQUARE 30" LEG FOR UNIT WITH MOUNTED RECEIVER	E281663
STD 42" EXTENDED SUPPORT LEG FOR 30" FAN UNIT	80540
MOTOR SERVICE DOOR PANEL	E86121